

OPERATOR'S MANUAL

UNIVAC 111

CONTENTS

Heading	Title	Page
SECTION 1. INTRODUCTION		
1-1.	About This Manual	1-1
1-2.	How to Read It	1-2
1-3.	Scope	1-2
1-4.	Organization	1-2
1-5.	UNIVAC III Data-Processing System	1-2
1-6.	Equipment of Advanced Design	1-2
1-7.	Processor Assembly	1-3
1-8.	Input-Output Units	1-3
1-9.	Magnetic-Tape Units	1-3
1-10.	Punched-Card Units	1-3
1-11.	High-Speed Printer	1-3
1-12.	Paper-Tape Unit	1-4
1-13.	Operator's Console	1-4
1-14.	You, The Operator, and What You Do	1-4
1-15.	Before Operation	1-4
1-16.	During Operation	1-4
1-17.	After Operation	1-5
1-18.	In Case of Trouble	1-5
SECTION 2. INFORMATION FILES		
2-1.	Definition	2-1
2-2.	Magnetic Tapes	2-1
2-3.	Storage and Handling	2-2
2-4.	Leader Repairs	2-3
2-5.	Splicing Broken Tape	2-3
2-6.	Punched Cards	2-5
2-7.	Arrangement of Decks	2-5
2-8.	Marking of Decks	2-5
2-9.	Storage and Handling of Cards	2-5
2-10.	Transporting Cards	2-6
2-11.	Jogging and Fanning Cards	2-7
2-12.	Loading and Unloading Cards	2-7
SECTION 3. OPERATOR'S CONSOLE MODEL 124		
3-1.	Description	3-1

Heading	Title	Page
3-2.	Control Panel and Keyboard..	3-1
3-3.	Monitor Panel	3-1
3-4.	Console Printer	3-4
3-5.	Operating Procedures	3-4
3-6.	Loading Paper	3-4
3-7.	Changing Ribbon	3-5
3-8.	Cleaning Type	3-5
3-9.	Removing and Replacing Type Box	3-5
3-10.	Turning on the System	3-6
3-11.	Setting Addressable Clock	3-7
3-12.	Interchanging Console Printers	3-7

**SECTION 4. UNISERVO III MAGNETIC-TAPE
UNIT MODEL 126**

4-1.	Description	4-1
4-2.	Tape-Transport System	4-1
4-3.	Position Detection	4-1
4-4.	Read-Write Circuits	4-1
4-5.	File Protection	4-5
4-6.	Operating Procedures	4-6
4-7.	Preparation: Daily Inspection	4-6
4-8.	Loading Tape	4-6
4-9.	Changing Tapes	4-6
4-10.	Changing Tape Wiper	4-7
4-11.	Exchanging Tape Units	4-8

**SECTION 5. UNISERVO IIA MAGNETIC-TAPE
UNIT MODEL 72**

5-1.	Description	5-1
5-2.	Tape-Transport System	5-1
5-3.	Position Detection	5-1
5-4.	Read-Write Circuits	5-1
5-5.	File Protection	5-5
5-6.	Operating Procedures	5-6
5-7.	Preparation: Daily Inspection	5-6
5-8.	Loading Tape..	5-6
5-9.	Changing Tapes	5-6
5-10.	Changing Tape Wiper	5-7
5-11.	Exchanging Tape Units	5-8

SECTION 6. CARD READER MODEL 133

6-1.	Description	6-1
6-2.	Card-Handling Mechanism	6-2
6-3.	Read Stations	6-2

Heading	Title	Page
6-4.	Controls	6-2
6-5.	Operating Procedures	6-2
6-6.	Preparation: Daily Inspection and Cleaning	6-5
6-7.	During Operation	6-5
6-8.	In Case of Trouble	6-6
6-9.	Misread and Rejected Cards	6-6
6-10.	Card Jams	6-6

SECTION 7. CARD READER MODEL 182

7-1.	Description	7-1
7-2.	Card-Handling Mechanism	7-2
7-3.	Read Stations	7-2
7-4.	Controls	7-2
7-5.	Operating Procedures	7-2
7-6.	Preparation: Daily Inspection and Cleaning	7-5
7-7.	During Operation	7-5
7-8.	In Case of Trouble	7-6
7-9.	Misread and Rejected Cards	7-6
7-10.	Card Jams	7-6

SECTION 8. CARD PUNCH MODEL 127

8-1.	Description	8-1
8-2.	Card-Handling Mechanism	8-2
8-3.	Punch Station	8-2
8-4.	Read Station	8-2
8-5.	Control Circuits	8-2
8-6.	Card Cycle	8-5
8-7.	Operating Procedures	8-5
8-8.	Preparation: Daily Inspection and Cleaning	8-5
8-9.	During Operation	8-5
8-10.	In Case of Trouble	8-5

SECTION 9. CARD PUNCH MODEL 183

9-1.	Description	9-1
9-2.	Card-Handling Mechanism	9-2
9-3.	Punch Station	9-2
9-4.	Read Station	9-2
9-5.	Control Circuits	9-2
9-6.	Card Cycle	9-5
9-7.	Operating Procedures	9-5
9-8.	Preparation: Daily Inspection and Cleaning	9-5
9-9.	During Operation	9-5
9-10.	In Case of Trouble	9-5

SECTION 10. HIGH-SPEED PRINTER MODEL 152

10-1.	Description	10-1
10-2.	Printing Mechanism	10-1
10-3.	Controls	10-2
10-4.	Operating Procedures	10-4
10-5.	Before Operation	10-4
10-6.	During Operation	10-8
10-7.	After Operation	10-8
10-8.	In Case of Trouble	10-10
10-9.	Paper Faults	10-10
10-10.	Faulty Printing	10-10

SECTION 11. PAPER-TAPE READ/PUNCH UNIT MODEL 181

11-1.	Description	11-1
11-2.	Reader and Reader Spooler	11-1
11-3.	Punch and Punch Spooler	11-2
11-4.	Controls	11-2
11-5.	Format Connector	11-3
11-6.	Operating Procedures	11-3
11-7.	Preparation: Daily Inspection and Cleaning	11-3
11-8.	During Operation	11-3
11-9.	Adjusting Feed Mechanism for Tape Width	11-3
11-10.	Changing Format Connector	11-3
11-11.	In Case of Trouble	11-3

SECTION 12. MAGNETIC CORE MEMORY

12-1.	General	12-1
12-2.	Memory Switches	12-1

ILLUSTRATIONS

Figure	Title	Page
1-1.	UNIVAC III Data-Processing System	1-1
2-1.	Tape and Leader Dimensions	2-2
2-2.	File-Protections Rings	2-3
2-3.	Leader-Clip Assembly, Wire Type	2-4
2-4.	Splicing Magnetic Tape	2-4
2-5.	Punched Cards	2-6
2-6.	Marked Packet	2-6
2-7.	Jogging Cards	2-7
2-8.	Fanning Cards	2-7
3-1.	Operator's Console Model 124	3-1

Figure	Title	Page
3-2.	Control Panel and Keyboard, Operator's Console Model 124	3-2
3-3.	Typical Monitor Panel	3-4
3-4.	Console Printer, Rear View	3-5
3-5.	Console Printer, Front View	3-6
3-6.	Type-Box Latch Operation	3-6
3-7.	Addressable Clock	3-7
3-8.	Console-Printer Connectors	3-7
4-1.	UNISERVO III Magnetic-Tape Unit Model 126 and Transition Cabinet	4-2
4-2.	UNISERVO III Tape Panel and Control Panel	4-3
4-3.	UNISERVO III Tape-Unit Control Panel	4-3
4-4.	Mounting Supply Reel	4-7
4-5.	Connecting Leaders, Plastic Leader/Connector	4-7
4-6.	Releasing Supply Reel	4-7
4-7.	Changing Tape Wiper	4-8
4-8.	UNISERVO III Tape-Unit-Select Patch Panel	4-8
5-1.	UNISERVO IIA Magnetic-Tape Unit Model 72 and Transistion Cabinet	5-2
5-2.	UNISERVO IIA Tape Panel and Control Panel	5-3
5-3.	UNISERVO IIA Tape-Unit Control Panel	5-4
5-4.	Mounting Supply Reel	5-7
5-5.	Connecting Leaders, Wire Clip Connector	5-7
5-6.	Releasing Supply Reel	5-8
5-7.	Changing Tape Wiper	5-8
5-8.	UNISERVO IIA Tape-Unit-Select Patch Panel	5-9
6-1.	Card Reader Model 133	6-1
6-2.	Card-Feed Path	6-2
6-3.	Card-Reader Control Panel	6-4
6-4.	Removing Brush Assemblies	6-6
6-5.	Inspecting Brushes	6-6
6-6.	Stackers, Top View	6-7
6-7.	Card-Reader Input Magazine	6-7
6-8.	Timing Wheel	6-7
7-1.	Card Reader Model 182	7-1
7-2.	Card-Feed Path	7-2
7-3.	Card-Reader Control Panel	7-4
7-4.	Removing Brush Assemblies	7-6
7-5.	Inspecting Brushes	7-6
7-6.	Stackers, Top View	7-7
7-7.	Card-Reader Input Magazine	7-7
7-8.	Timing Wheel	7-7
8-1.	Card Punch Model 127	8-1
8-2.	Card-Feed Path	8-2
8-3.	Card-Punch Control Panel	8-2
8-4.	Unlocking Punch Block	8-6
8-5.	Raising Punch Block	8-6
8-6.	Removing Chip Box	8-6
8-7.	Clearing Die Slot	8-7
8-8.	Locking Brush Assembly	8-7
9-1.	Card Punch Model 183	9-1
9-2.	Card-Feed Path	9-2
9-3.	Card-Punch Control Panel	9-2
9-4.	Unlocking Punch Block	9-6
9-5.	Raising Punch Block	9-6
9-6.	Removing Chip Box	9-6
9-7.	Clearing Die Slot	9-7
9-8.	Locking Brush Assembly	9-7
10-1.	High-Speed Printer Model 152	10-1
10-2.	Printing Mechanism, Simplified	10-2
10-3.	High-Speed Printer Controls	10-2
10-4.	Removing Front Guide Roller	10-7
10-5.	Loading New Ribbon	10-7

Figure	Title	Page
10-6.	Starting Ribbon on Takeup Mandrel	10-7
10-7.	Replacing Front Guide	10-7
10-8.	Ribbon Edge Sensing Switch	10-9
10-9.	Paper-Feed Tractors	10-9
10-10.	Inserting Paper	10-9
10-11.	Adjusting Tractors	10-9
11-1.	Paper Tape Read/Punch Unit Model 181, Reader Side .	11-1
11-2.	Paper Tape Read/Punch Unit Model 181, Punch Side .	11-1
11-3.	Tape Handler and Panels	11-2
11-4.	Punch 1 and Takeup Spooler Panel	11-2
11-5.	Reader Control Panel	11-3
11-6.	Punch Controls Panel	11-3
11-7.	Punch and Supply Spooler	11-8
11-8.	Format Connector and Chad Bin	11-8
12-1.	Memory-Stack Switch Location	12-1
12-2.	Memory Arrangement	12-1

TABLES

Table	Title	Page
1-1.	Preparation of Materials	1-4
1-2.	Preparation of Input-Output Equipment Before Operation . .	1-5
1-3.	Duties During Operation	1-5
1-4.	Duties After Operation	1-6
3-1.	Controls and Indicators, Operator's Console	3-2
4-1.	Controls Panel, UNISERVO III Magnetic-Tape Unit Model 126	4-4
4-2.	Tape-Panel Controls and Devices, UNISERVO III Tape Unit .	4-5
4-3.	Protective Devices, UNISERVO III Tape Unit	4-5
4-4.	Tape-Loading Procedure, UNISERVO III Tape Unit	4-6
4-5.	Tape-Changing Procedure, UNISERVO III Tape Unit	4-7
5-1.	Control Panel, UNISERVO IIA Magnetic-Tape Unit Model 72	5-4
5-2.	Tape-Panel Controls and Devices, UNISERVO IIA Tape Unit	5-6
5-3.	Protective Devices, UNISERVO IIA Tape Unit	5-6
5-4.	Tape-Loading Procedure, UNISERVO IIA Tape Unit	5-7
5-5.	Tape-Changing Procedure, UNISERVO IIA Tape Unit	5-8
6-1.	Control Panel, Card Reader Model 133	6-3
6-2.	Card-Reader Inspection and Cleaning	6-5
6-3.	Removing and Replacing Brush Assemblies	6-5
6-4.	Cleaning Card Path	6-6
6-5.	Refeeding Rejected Sequence-Sensitive Cards	6-6
6-6.	Clearing Card Jams	6-8
7-1.	Control Panel, Card Reader Model 182	7-3
7-2.	Card-Reader Inspection and Cleaning	7-5
7-3.	Removing and Replacing Brush Assemblies	7-5
7-4.	Cleaning Card Path	7-6
7-5.	Refeeding Rejected Sequence-Sensitive Cards	7-6
7-6.	Clearing Card Jams	7-8
8-1.	Control Panel, Card Punch Model 127	8-3
8-2.	Card-Punch Inspection and Cleaning	8-5
8-3.	Clearing Stacker Jams	8-6
8-4.	Clearing Punch-Station Jams	8-7

Table	Title	Page
7-2.	Card Reader Inspection and Cleaning	7-5
7-3.	Removing and Replacing Brush Assemblies	7-5
7-4.	Cleaning Card Path	7-6
7-5.	Refeeding Rejected Sequence-Sensitive Cards	7-6
7-6.	Clearing Card Jams	7-8
8-1.	Control Panel, Card Punch Model 127	8-3
8-2.	Card-Punch Inspection and Cleaning	8-5
8-3.	Clearing Stacker Jams	8-6
8-4.	Clearing Punch-Station Jams	8-7
8-5.	Clearing Throat Jams	8-8
9-1.	Control Panel, Card Punch Model 183	9-3
9-2.	Card-Punch Inspection and Cleaning	9-5
9-3.	Clearing Stacker Jams	9-6
9-4.	Clearing Punch-Station Jams	9-7
9-5.	Clearing Throat Jams	9-8
12-1.	Effects of Memory-Switch Operation, Cabinet 1	12-2
12-2.	Effects of Memory-Switch Operation, Cabinet 2	12-2

Section 1

INTRODUCTION

1-1. ABOUT THIS MANUAL

This manual tells and shows how to operate the most advanced large-scale electronic data-processing system now available to the business world, the UNIVAC[®] III Data-Processing System (figure 1-1). It is intended primarily as a textbook of operating procedures and, therefore, contains only that

general information you must have to understand fully your duties and responsibilities. It is meant to supplement, not to replace, operator training courses or other instructor-directed training.

A secondary purpose of this book is to provide a convenient source of necessary but infrequently used information, arranged for easy reference.

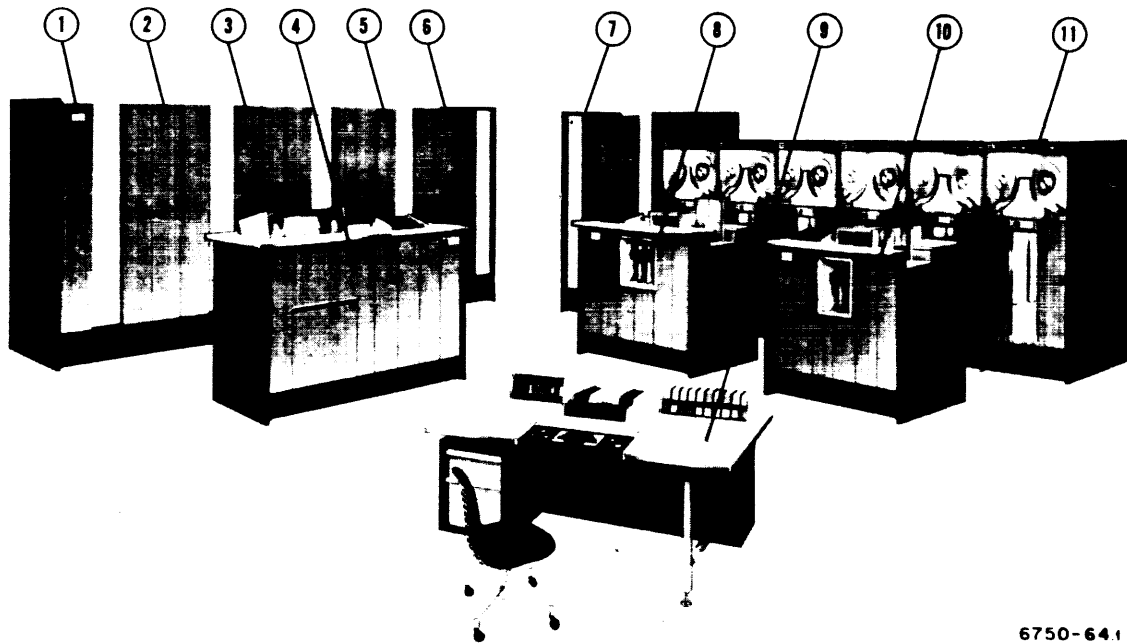

6750-64.1

1. Memory Unit
2. Central Processor
3. UNISERVO Synchronizer
4. High-Speed Printer
5. Power-Control Section
6. Central Power Supply
7. UNISERVO Power Supply and Transition Cabinet
8. Card Reader
9. Operator's Console
10. Card Punch
11. UNISERVO Magnetic-Tape Unit

Figure 1-1. UNIVAC III Data-Processing System

The following registered trademark of the Sperry Rand Corporation is used in this manual: UNIVAC.

1-2. How to Read It

If you are a member of a formal class, your instructor will make study assignments to fit the needs of the course. If you are not in a formal class, it is suggested that you read it in the following way:

(1) Read the rest of this section and section 2 for general information.

(2) Read the table of contents and look through the entire book to become familiar with the organization and style of the sections.

(3) Study the equipment sections. Each section is complete in itself, so you may take them in any order.

(4) Review what you have studied. Review for several consecutive days after your first reading, then once or twice a week until all operating procedures have become second nature.

1-3. Scope

This manual contains background information, and descriptions of and operation instructions for equipment components of the UNIVAC III system.

The background material presents a concept of the system and an orientation to your duties. The equipment descriptions emphasize operation controls and equipment functions as they affect your duties. Operation instructions are presented in step-by-step form, with illustrations to show certain techniques, and include only those tasks that do not require the use of tools.

The manual does not contain operation instructions for programs or routines. Such information is contained in the operator's software reference manuals.

1-4. Organization

The first two sections of this manual are a general introduction to the manual, the system, your duties, and the handling of materials common to many data-processing systems.

Sections 3 through 12 describe the equipment you operate and give detailed operating procedures. A typical equipment section has the following organization:

(1) Description:

(a) Physical,

(b) Functional.

(2) Operating procedures;

(a) Preparation of equipment,

(b) On-line operation,

(c) Duties after operation, and

(d) Correction of abnormal conditions.

Each equipment section is self-contained to allow the insertion or removal of sections as required. This feature provides for the addition of sections on new equipment that may become available for inclusion in the system, or for changes resulting from modification of existing equipment.

1-5. UNIVAC III DATA-PROCESSING SYSTEM

The UNIVAC III Data-Processing System is a high-speed, large-scale electronic computing system of advanced design and versatile input-output capability. But an electronic data-processing system is more than a collection of computer equipment. The equipment, or hardware, as it is sometimes called, is only one of three elements essential to an efficient, productive system.

The second essential element is a list of computer-language instructions to control the operation of the computer. These instructions are combined into programs—groups of instructions that cause the computer to perform an operation or series of operations. Some of these programs are supplied by the UNIVAC Division to simplify programming (the planning and writing of programs) and operation, and to provide comprehensive and powerful test and diagnostic aids for the maintenance staff.

The third element of the system is the staff of skilled men and women who prepare problems for solution on the computer, maintain the hardware, and operate the system. The productivity of the system depends as much upon the efficiency of this group as upon any other single factor.

1-6. EQUIPMENT OF ADVANCED DESIGN

The computer equipment of the UNIVAC III system consists of a processor assembly, an operator's console, input-output units, and power supplies. The system may use up to 38 magnetic-tape units and 8 additional input-output units. The design of the system enables each user to select the input-output units and memory capacity he needs. Groups of circuits called synchronizers link the high-speed central processor and the slower input-output units. A synchronizer carries out the detailed execution of a program instruction for an input-output operation.

while the central processor proceeds with other computation.

1-7. Processor Assembly

The processor assembly contains the central processor, the memory (core storage) cabinets, UNISERVO* synchronizers, the central power supply, and the power controls for the system.

The central processor performs all the data-processing functions in the UNIVAC III system and coordinates the operation of all input-output devices in the system. The processor also receives and checks all input data from memory and controls the transfer of this data between the memory, the arithmetic units, and the input-output units. The processor can communicate with up to eight external input-output-unit synchronizers, in addition to the UNISERVO synchronizers.

A memory cabinet contains a high-speed, random-access magnetic-core memory and a memory power supply. A UNIVAC III memory has a capacity range of 8192 to 32,768 computer words, in multiples of 8192 words.

The UNISERVO synchronizers are the only input-output synchronizers in the processor assembly. They link the high-speed central processor with the slower UNISERVO tape units.

The central power supply provides the power to operate the central processor and UNISERVO synchronizers; the power-control section controls the power distribution to the entire system.

1-8. Input-Output Units

Input-output units, described in detail in sections 4 through 11, fall into four groups, as follows:

- (1) Magnetic-tape units,
- (2) Punched-card units (readers and punches),
- (3) High-speed printers, and
- (4) Paper-tape read/punch units.

Each input-output unit cabinet, except UNISERVO tape units, contains the synchronizer for that unit.

Each input-output unit has a control panel that provides limited control of the unit and gives indications of abnormal conditions within the unit. You must use the unit control panels during such opera-

tions as loading and unloading tapes, cards, or paper.

1-9. MAGNETIC-TAPE UNITS. The UNISERVO III Magnetic-Tape Unit Model 126 and the UNISERVO IIA Magnetic-Tape Unit Model 72 are the principal input-output devices of the UNIVAC III system.

UNISERVO tape units and tapes have functions similar to those of ordinary home tape recorders and tapes, except that they record, store, and play back binary-coded information instead of voices or music. The UNISERVO tape unit is far more complex than a home tape recorder, however, because of the requirements of automatic operation, high speed, and precise control. Tape moves almost 15 times as fast on UNISERVO tape units as on home tape recorders.

A tape unit moves tape past a magnetic-head assembly that writes (records) data by magnetizing small areas of the tape, or reads (plays back) data by detecting the magnetized areas. When the tape has been filled, or when the system needs no more information from the tape, the tape unit, on command, rewinds the tape.

UNISERVO tape units do not contain power supplies. A UNISERVO Power Supply Model 123, in a separate cabinet at the end of a group of tape units, supplies power for up to 16 tape units.

The UNIVAC III system may use up to 32 UNISERVO III magnetic-tape units for data input and output, and for auxiliary memory. In addition, the system may use up to six UNISERVO IIA magnetic-tape units for input-output compatibility with other data-processing systems and for direct magnetic-tape input from manually-prepared tapes.

1-10. PUNCHED-CARD UNITS. The card reader is a major input device of the UNIVAC III system. Two models provide compatibility with 80-column and 90-column punched-card tabulating systems: either model reads up to 700 cards per minute. A system may use several readers, either all of the same model, or one or more of each model. Cards may be prepared (1) off line (that is, on a unit not connected to the UNIVAC III system) by any one of a variety of card punching devices; or (2) on line by a card punch in the UNIVAC III system.

The card punch provides the punched-card output facility for the system. Several units, either 80-column or 90-column or both, may be used in the same UNIVAC III system. Each card punch can punch up to 300 cards per minute. The system program determines the format of the punched information.

1-11. HIGH-SPEED PRINTER. The high-speed printer prints up to 700 lines per minute of alphabetic

*Trademark of the Sperry Rand Corporation.

or alphanumeric (alphabetic and numeric combined) information, or up to 922 lines per minute of completely numeric information. The paper-feed mechanism uses continuous-form, sprocket-fed paper, and may be adjusted for forms from 4 inches through 22 inches wide. The computer program controls the printing format, including paper spacing.

1-12. PAPER-TAPE UNIT. The input-output equipment may include a paper-tape read/punch unit for input-output compatibility with paper-tape equipment of telegraphic communications systems, or with business systems that use perforated-tape equipment.

1-13. Operator's Console

The operator's console contains the controls and indicators by which you control and follow the operation of the system during data-processing operations. The console equipment consists of a control panel, a keyboard, a console printer (typewriter), a monitor panel, and an addressable clock, sometimes called a real-time clock to distinguish it from the electronic clock that synchronizes the operation of the system.

The control panel contains power controls for the system, load and rewind controls for the master instruction tape (MIT), console printer controls and indicators, and central-processor controls and indicators.

The keyboard, similar to an electric typewriter keyboard, enables you to type information requested by the program, such as the problem or run number, identification of data and output tapes, and the storage functions available.

The console printer, under program control, may print requests for information, problem-identification data, test and diagnostic information, or other program-directed messages. It may also print all information you type in from the keyboard.

The monitor panel contains indicator lamps that light to show that a unit in the system needs attention. The monitor panel directs your attention to the unit; indicators on the unit control panel identify the condition that caused the indication.

The addressable clock provides a real-time, or time-of-day, reference for the system to enable it to record the actual time operations or problems start or end, or the length of time used to perform an operation.

1-14. YOU, THE OPERATOR, AND WHAT YOU DO

You might expect that the size and complexity of the UNIVAC III system would make it difficult to operate.

Nothing could be farther from the truth.

The UNIVAC III system is actually easier to operate than many less complex systems because the size and complexity of the system make possible advanced methods of control.

The following paragraphs list the duties you must perform. Later sections contain the detailed descriptions of the tasks listed here. Tasks that relate to off-line files are described in section 2. Tasks that involve the operator's console printer are described in section 3. Tasks you must perform at input-output units are described under Operating Procedures in sections that pertain to input-output units.

Your duties include the preparation of materials and equipment at the beginning of the operating shift; routine care and cleaning of parts of the input-output equipment; running programs; and the removal and care of tapes, punched cards, and printed output data.

1-15. Before Operation

Table 1-1 lists the materials to be assembled and prepared at the beginning of the shift. The Remarks column gives sources of materials, precautions, and references to sections where you may find further information. Table 1-2 lists the tasks you must perform to prepare the input-output equipment for the day's operation. Refer to Operating Procedures in the appropriate section for the procedure for each task.

Table 1-1. Preparation of Materials

Material	Remarks
Operating instructions.	From programmer, in run book.
Magnetic tapes: Program, data, and blank.	Inspect for file-protection or write-enable rings, condition of leaders. Refer to section 2.
Punched-card decks for card reader.	Keep compressed until loaded. Refer to section 2.
Blank cards for punch.	

1-16. During Operation

Table 1-3 lists the tasks you may be required to perform during an operating shift. Tasks listed for each unit appear in the approximate order of frequency with which you will perform them.

Table 1-2. Preparation of Input-Output Equipment Before Operation

Unit	Task	Remarks
Complete System	Turn on system.	Refer to operating procedures for operator's console.
UNISERVO IIA and UNISERVO III Tape Units	Inspect and clean tape path on all tape units.	Refer to operating procedures for UNISERVO IIA and UNISERVO III tape units.
	Connect tape-unit patch cords as required.	Enter changes in appropriate log, change numeral blocks. Refer to operating procedures for tape units.
Card Reader and Punch	Clean and inspect feed track in card reader and punch.	Refer to operating procedures for card readers and punches.
	Empty card-punch chip box.	Refer to operating procedures for card punches.
	Load card input hoppers.	Refer to section 2 and sections on card units.
Printers	Load, thread, and align paper in high-speed printer and console printer.	Refer to operating procedures for high-speed printer and console printer.
	Inspect ribbons in high-speed printer and console printer.	Replace if necessary. Refer to operating procedures for high-speed printer and console printer.
Console	Verify setting of addressable clock.	Reset if necessary. Refer to operating procedures.
Paper-Tape Read/Punch	Clean and inspect tape paths in paper-tape unit.	Refer to operating procedures for paper-tape read/punch unit.
	Empty chad bin.	
	Load punch supply spool if necessary.	

Table 1-3. Duties During Operation

Unit	Task	Remarks
UNISERVO IIA and UNISERVO III Tape Units	Change tapes.	Refer to operating procedures for UNISERVO IIA and UNISERVO III tape units.
	Exchange tape units.	
	Thread leaders.	
	Repair tapes.	Refer to section 2.
Card Reader and Punch	Reload input magazines.	Refer to operating procedures for card readers and punches.
	Empty stackers.	
	Refeed misread and rejected cards.	
	Clear card jams.	
High-Speed Printer and Console Printer	Reload paper.	Refer to operating procedures for high-speed printer and console.
	Change ribbons.	
	Exchange console printers.	
Memory Units	Switch memory stacks.	Refer to operating procedures for memory units.

1-17. After Operation

Table 1-4 lists the duties you must usually perform at the end of an operating shift. Duties may be added to or removed from this list at the discretion of your supervisor.

1-18. In Case of Trouble

If trouble that you cannot easily correct occurs during the running of a program, first take immediate action to safeguard equipment if such action is needed, then notify your supervisor. If the trouble is a machine error, it may be possible to continue operating under handicapped conditions. If the trouble is a program error, it may be necessary to remove from the system the problem in which the trouble occurred, and continue operation on another problem. In either case, follow your supervisor's instructions.

Table 1-4. Duties After Operation

Unit	Task	Remarks
UNISERVO IIA and UNISERVO III Tape Units	Rewind and unload all tape remaining on tape units.	Refer to operating procedures for UNISERVO IIA and UNISERVO III tape units.
	Label and file all tapes.	Refer to section 2 and run book.
Card Reader and Punch	Unload and file any cards remaining in input magazines.	Refer to section 2.
	Remove and file cards from output stackers.	
	Clean feed tracks.	Refer to operating procedures for card readers and punches.
	Empty punch chip box.	
High-Speed Printer and Console Printer	Unload output pages and deliver to your supervisor.	
Paper-Tape Read/Punch	Unload and file punch output.	Refer to operating procedures for paper-tape read/punch unit.
	Empty chad bin.	
Complete System	Turn off power if no operating or maintenance shift follows.	

Section 2

INFORMATION FILES

2-1. DEFINITION

Files are devices that store information for later use. They may consist of metal or plastic magnetic tapes, punched cards, or perforated paper tapes. They may contain (1) output data from past computer runs, (2) programs, or (3) input data for future computer runs. Although such files may be prepared on line, that is, by the computer, they may also be prepared off line on such equipment as a UNITYPER* II, magnetic-tape typewriter, a UNIVAC Input Verifier, an 80-column or 90-column keypunch, or a keyboard-operated paper-tape punch.

Information is written or punched in off-line files in binary form, that is, as binary 1's or 0's. Magnetic tapes store information as small magnetized areas; punched cards and paper tape store information as holes, according to a number-and-position code.

2-2. MAGNETIC TAPES

Two types of magnetic tape are used with UNIVAC systems. Metal tapes electroplated with a magnetic alloy are used with UNISERVO IIA tape units and with the earlier UNISERVO I tape units. Oxide-coated Mylar¹ plastic tapes are used with UNISERVO III tape units, and may be used with UNISERVO IIA tape units. Plastic tapes for UNISERVO IIA and UNISERVO III tape units are not interchangeable.

To record information on magnetic tape, the system applies a pulse of electric current to the read-write head of a tape unit. The pulse generates a magnetic field in the head, and magnetizes the small area of tape that is in contact with the head.

To read the information, the read heads detect the magnetized areas as the tape moves past the head. Because of differences between the recording methods used for UNISERVO IIA and UNISERVO III tape units, tapes prepared on one type of tape unit cannot be read by the other.

Sections of tape unsuitable for recording, called **bad spots**, are marked either mechanically or electronically; detection devices sense the markings, and the system disregards information in the marked areas.

Bad spots on metal tapes used on UNISERVO IIA tape units are marked by holes punched at 2-1/2-inch intervals along the tape; photocells detect the holes and cause the system to delay writing or reading until the bad area has passed the head. Bad spots on plastic tapes for UNISERVO IIA tape units are marked by 1/8-inch transparent windows across the tape at 2-1/2-inch intervals along the tape. The windows are prepared by scraping the oxide coating from the surface of the transparent Mylar base.

Bad spots on tapes used on UNISERVO III tape units are marked electronically by the system.

Figure 2-1a shows the dimensions of metal tapes and reels. Figure 2-1b shows the dimensions of plastic tapes and reels.

The approximate weights of full tape reels are as follows:

8-inch metal	4-1/2 pounds
6-inch metal	1-1/4 pounds
10-inch plastic	2-1/2 to 3-1/4 pounds

Master files need protection against accidental erasure or change. To protect the contents of master files used on UNISERVO III tape units, remove the plastic ring from the rear face of the master-tape reel (figure 2-2a). When the ring is in place, it operates switches in the reel hub to connect the writing and erasing circuits of the tape unit; when the ring is removed, it allows the writing and erasing circuits to remain disconnected. Master files used on UNISERVO IIA tape units are protected in a

*Trademark of the Sperry Rand Corporation.

¹Trademark of E.I. du Pont de Nemours and Co., Inc. Wilmington, Del.

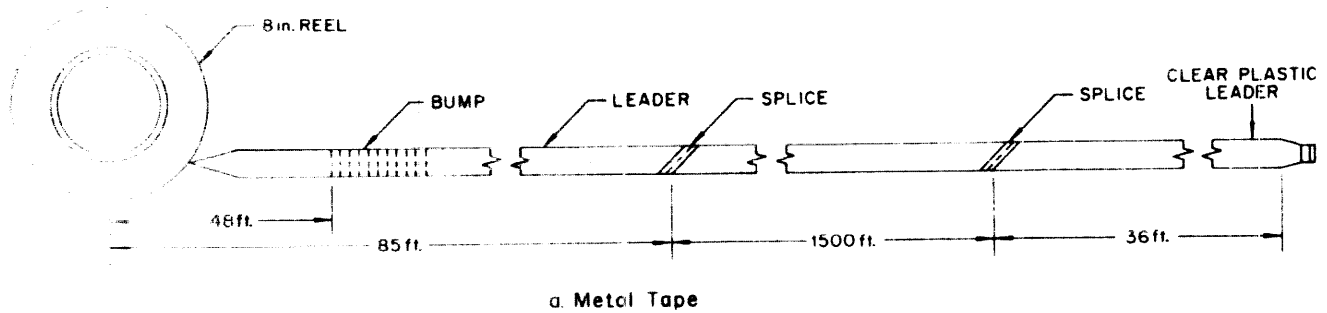

UNISERVO III TAPE

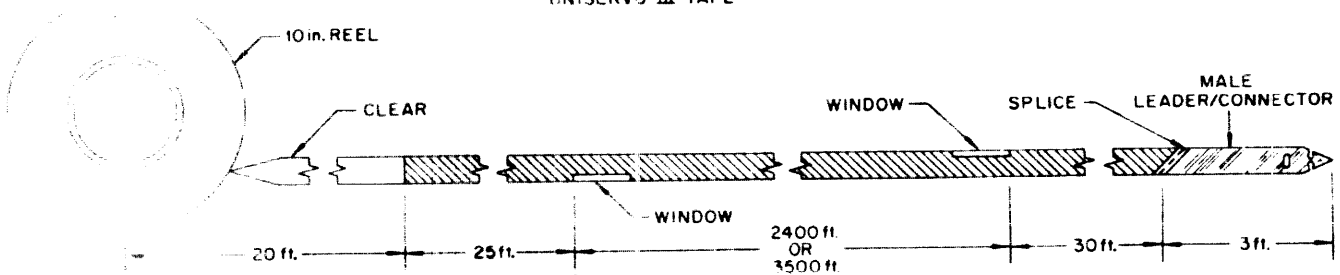

UNISERVO IIA PLASTIC TAPE

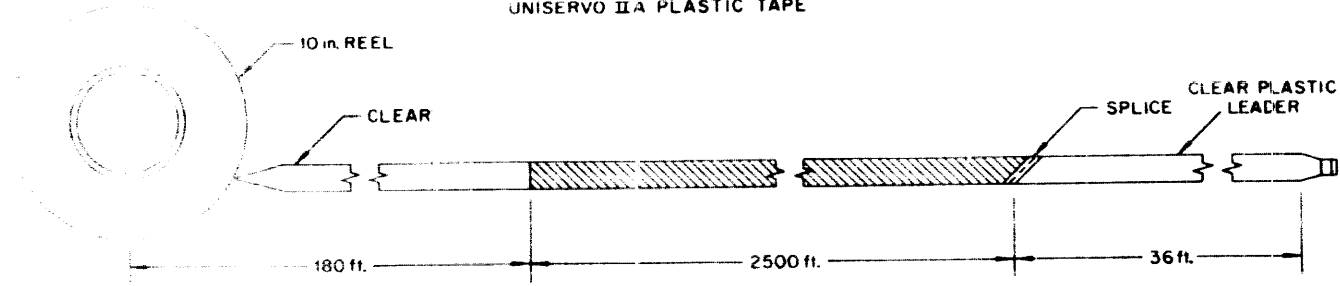

b Plastic Tapes

NOTE
ALL DIMENSIONS APPROXIMATE

8190

Figure 2-1. Tape and Leader Dimensions

similar way; however, with UNISERVO IIA reels, you must insert a metal ring in the hub of the reel (figure 2-2b). The ring in a UNISERVO IIA reel operates switches that disconnect the writing and erasing circuits in the tape unit on which the reel is mounted.

2-3. Storage and Handling

Store magnetic tape reels on edge in closed cabinets to protect them from dust, which can foul magnetic heads on tape units. Use an elastic band or some other approved device to keep the tape tight on the reel.

Use a cart with a tape rack to move tapes from the library to the operating area. Don't stack tape reels one on top of another, especially on carts; tape reels can slide like phonograph records.

In the operating area, handle tapes one at a time. Keep tapes on the tape cart or in a cabinet, and never lay tapes on top of tape units or other cabinets where they may pick up dust, become heated, or block the flow of cooling air.

Be sure that all master-tape reels are properly protected from accidental erasure (heading 2-2); be sure also that all tapes on which information is to be written are not protected.

Read labels. When you take a reel from the library cabinet, be sure that the reel label and the shelf label agree. Verify the label again when you load the tape



5746

a. UNISERVO III Write-Enable Ring

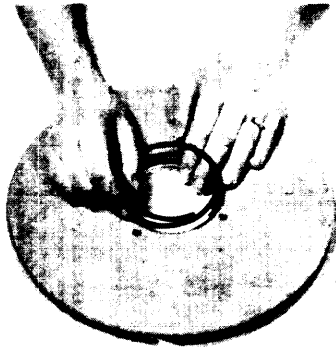

6002

b. UNISERVO IIA Write-Inhibit Ring

Figure 2-2. File-Protection Rings

on a tape unit. Finally, double-check the label when you return the tape to the library file cabinet.

Label all output tapes according to run book description.

2-4. Leader Repairs

A tape leader is a section of plastic tape that is spliced to the beginning of a magnetic-recording tape. The free end of the leader has a fastening device—a wire clip or a plastic tongue—to fasten the tape leader to the machine leader.

A leader that breaks in the tape portion should be replaced; a leader that breaks at the connector may be repaired. Male leader/connectors for plastic tapes

(figure 2-1) and plastic leaders for metal tapes should be spliced to the tape in the same way a broken tape is spliced. To replace a metal clip, proceed as follows:

- (1) Fold end of the leader back on itself for about 1/2 inch, align edges, and punch a hole through layers near free end.
- (2) Trim and taper folded leader as shown in figure 2-3.
- (3) Fold leader over 1/4-inch insert-pin and align punched holes. Slip split retainer over leader and pin (figure 2-3). Tapered tongue should face center of reel when tape is wound onto reel. Be careful to keep assembly square—punched holes show whether it is.
- (4) Fasten tongue with a piece of splicing tape.
- (5) Slip ends of wire clip into open ends of retainer. The open side of a hooked clip should face away from recording side of the tape.

2-5. Splicing Broken Tape

A tape that breaks during use must be rewound and removed from the tape unit. The amount of information lost adjacent to the break is usually great enough to require the re-creation of the tape. To rewind the tape, however, you must first splice the broken ends.

To splice a broken tape, proceed as follows:

- (1) Push OFF button on tape-unit control panel and open tape-panel door.
- (2) Pull off a convenient length of tape from both reels and cut off and discard damaged parts of the tape.
- (3) Place tape in a splicing bar with ends overlapping and cut both ends, as shown in figure 2-4a. Remove scraps. Be careful not to twist tape.
- (4) Butt the ends together and apply splicing tape (figure 2-4b). Rub tape with a smooth, hard tool (a tape weight will do) to remove air bubbles and ensure a good bond.
- (5) Turn tape over and repeat step 4.
- (6) Trim the splice as shown in figure 2-4c.
- (7) Mark metal tapes with a bad-spot marking punch 1-1/4 inches from splice, on both sides of splice (figure 2-4d). Mark plastic tapes used on

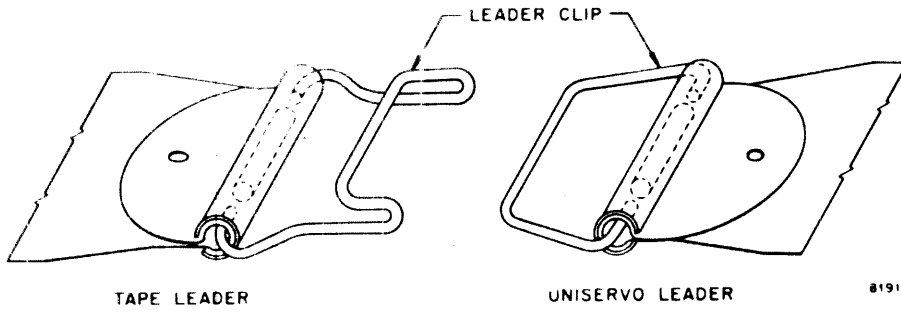
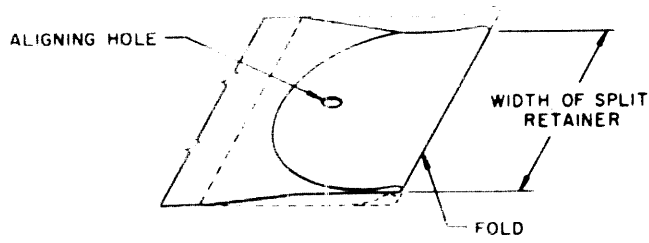
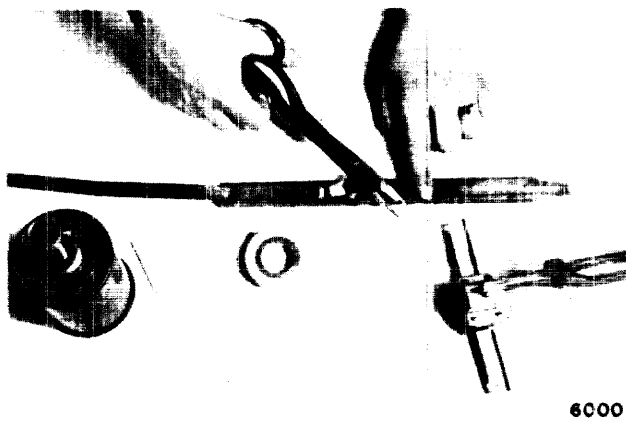
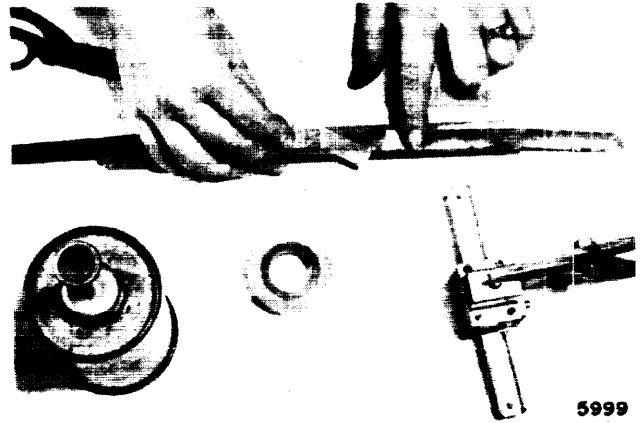

Figure 2-3. Leader-Clip Assembly, Wire Type



a. Trimming Ends



b. Applying Splicing Tape

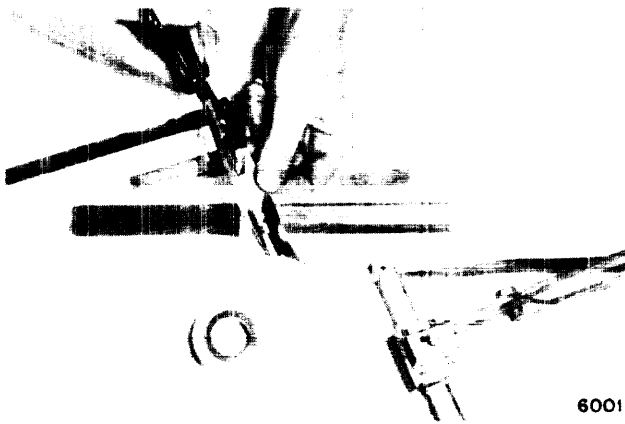

c. Trimming Splice



d. Bad-Spot Marking (Metal Tape Only)

Figure 2-4. Splicing Magnetic Tape

UNISERVO IIA tape units by scraping away oxide coating from a 1/8-inch wide strip across tape, 1-1/4 inches from splice on both sides of splice. Do not scrape plastic tapes used on UNISERVO III tape units.

(8) Mark the reel **SPLICED** to show that it does not hold a full-length tape.

(9) Rethread the tape, rewind it, and remove it from the tape unit.

(10) Record the program designation, tape number, tape-unit number, and time in the appropriate log.

NOTE

Do not return spliced UNISERVO III tapes to storage. A UNISERVO III tape may be read to recover data immediately after it has been spliced, but a tape containing a splice must not be used on a UNISERVO III tape unit after it has been stored. The undamaged portions may be respooled and used as short tapes.

2-6. PUNCHED CARDS

Precision-cut cards of high-quality heavy paper stock, used with punched-card accounting and tabulating systems, may also be used with the UNIVAC III system for off-line information storage. These cards are manufactured to rigid standards for size, thickness, strength, and dimensional stability under varying conditions. A card stores information in a coded pattern of punched holes. Figure 2-5 shows two cards, one with 80-column punching, and one with 90-column punching.

An 80-column card (rectangular holes) has 80 vertical columns across the card. A 90-column card (round holes) has 45 vertical columns across the card in each of two fields, an upper field and a lower field.

Cards that are compatible with tabulating-system codes can have one, and only one, character punched in each column. Another type of coding, called binary-image coding, may be used on cards prepared for electronic computer use. Binary-image cards are usually prepared on-line by the system, and often have more holes per card than cards prepared with tabulating-system codes.

2-7. Arrangement of Decks

A group of cards that belong together is called a packet, file, or deck. Decks are stored in drawers or trays with the printed side of the cards toward

the front of the drawer so that interpreted cards may be easily read. (An interpreted card is one on which the information punched in the card has been translated and appears printed on the face of the card.) Cards in decks in which sequence is significant are numbered serially, and the information on the card, including the serial number, may be interpreted on the face of the card.

In 80-column readers and punches, cards are fed face down, the row-9 edge toward the feed throat; therefore, the first card in a deck of punched cards is toward the front of the file drawer. In decks sorted in numerical order (low-to-high), the lowest numbered card of the deck will be toward the front of the drawer.

In 90-column readers and punches, cards are fed face up, lower field toward the feed throat; therefore, the lowest numbered card in the deck is toward the rear of the file drawer (card faces to the front).

2-8. Marking of Decks

A packet or a deck (figure 2-6), is frequently marked with a felt pen diagonally along one edge of the deck, if the deck is thick enough. Such marking serves to identify the deck, either by some alphanumeric designation or by a pattern of marks, and, if the cards were in proper order when marked, shows when a card is out of order. If the marking is smooth and regular after you have jogged the cards (heading 2-11), the cards are in proper order. Cards out of order (figure 2-6) make the edges of the marking appear rough or irregular.

2-9. Storage and Handling of Cards

Punched-card units are precision equipment and are adjusted to close tolerances. Cards that are torn, frayed, creased, bent, or swelled by moisture may not only be incorrectly read but may also cause jams in the card units. Punched cards are stored in cabinets especially designed to keep card files in the best possible condition. The cards rest in a tray that holds them immovable under compression. When you take cards from the library, you may take the entire tray from its storage cabinet. The cards need not be disturbed until they are loaded into an input magazine.

Blank cards are stored in close-fitting corrugated cardboard trays in sealed, moisture-proof cartons, five trays to a carton. A tray contains 2000 cards and weighs 11-1/4 pounds; a carton contains 10,000 cards and weighs about 60 pounds.

Cartons of cards should be protected from dampness and heat and should be allowed to come to room temperature before the carton is opened. Cards that

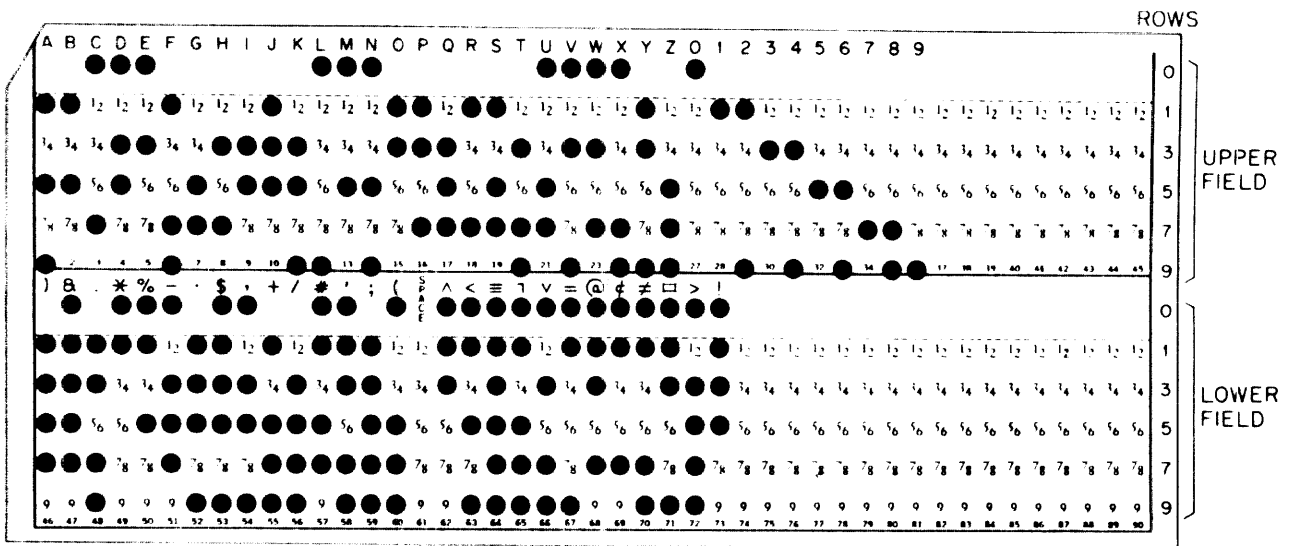

a. 90-Column Card

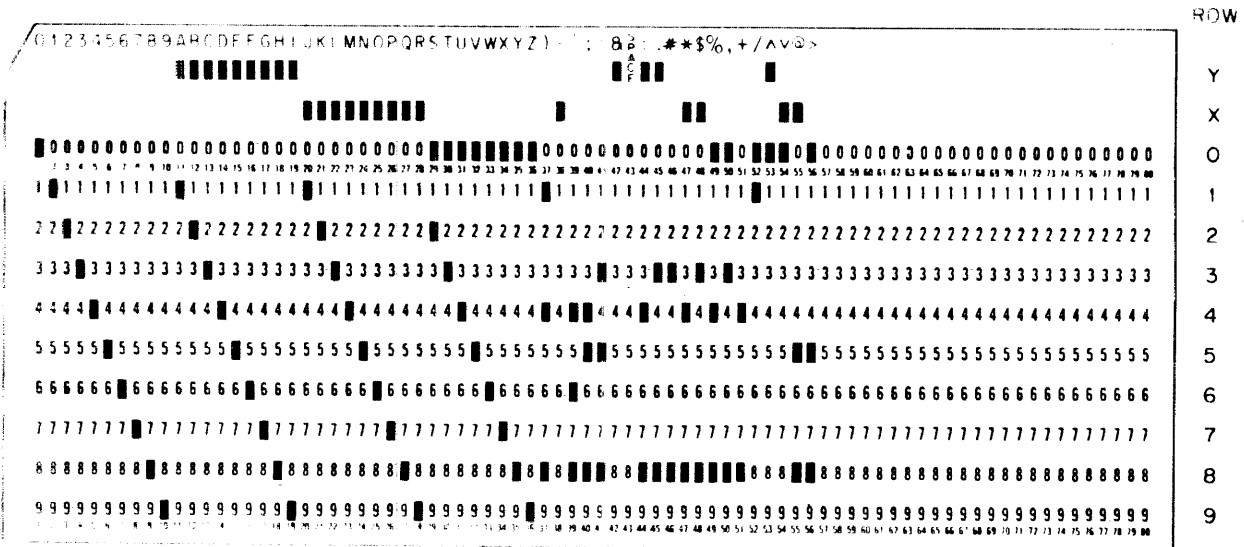

b. 80-Column Card

3534

Figure 2-5 Punched Cards

are colder than room temperature will attract and absorb moisture (by condensation) if exposed to room air. Moisture will cause cards to swell and may, therefore, cause feeding problems.

The following paragraphs explain how to handle and care for cards to ensure that they feed smoothly through the card reader or card punch and are filed or refiled in correct order.

2-10. TRANSPORTING CARDS. The best way to carry cards from one place to another is in a card-file tray on a library cart. The tray protects the edges of the cards and keeps them under compression; the cart saves your back—a full card tray weighs about 26 pounds and contains 3000 cards.

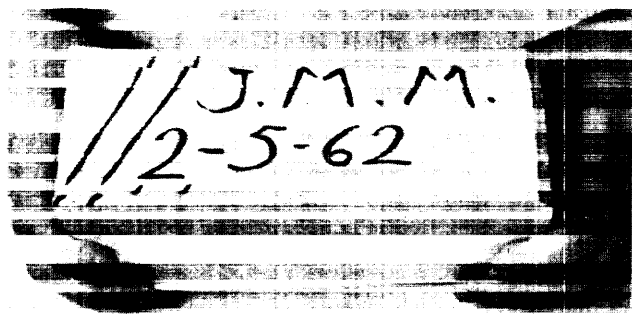

5740

Figure 2-6. Marked Packet

If you need several short decks from different storage drawers, put them all in a spare tray under compression, with separators between the decks. Move the follower in each tray to compress the remaining cards. Always keep decks compressed, except when you are actually using them.

2-11. JOGGING AND FANNING CARDS. After you have inspected the cards, and before you place them in the magazine, you must fan them to be sure they do not stick together and jog them to align them. Fanning removes any static charge that might cause two cards to stick together; jogging evens the edges of the deck so that the cards will feed smoothly through the magazine.

To jog cards (figure 2-7), take a 2-inch-thick bundle (about 300 cards) and place it on edge on a jogging plate on the card unit. Support the bundle loosely against the fence with one hand, lift and drop the other end of the bundle several times with your open hand, and at the same time gently push the bundle against the fence. Keep the bundle loose to let the cards slide into place. When the cards are aligned, grasp the bundle firmly and lift it from the jogging plate.

CAUTION

When you handle cards, take care not to score or dent the edges of the cards. Dropping cards, allowing them to hit against a sharp edge, or scratching or rubbing a finger ring against the edges of cards may damage edges enough to cause a feed jam.

To fan cards, take a jogged bundle and hold it firmly by one end. Bend the other end back and riffle it several times (figure 2-8). Repeat the process with the other end of the bundle. Jog cards before and after fanning them.

2-12. LOADING AND UNLOADING CARDS. Although the detailed loading and unloading procedures are slightly different for punches and readers, the general card-handling procedures are the same for all units.

Fan and jog cards before you load them into an input magazine, and jog cards removed from a stacker before you place them in a storage tray. Observe the condition of all cards you handle, and notify your supervisor when any card appears damaged; don't load damaged cards.

Load 80-column cards face down in the input magazine, with the row-9 edge (bottom of the card) toward the feed throat. Load 90-column cards face up, lower field toward the feed throat.



Figure 2-7. Jogging Cards



Figure 2-8. Fanning Cards

To unload an output stacker, either wait until a full stacker stops the unit, or stop the unit from the control panel before you remove cards from the stacker.

Operator's Manual

Don't try to remove cards from an output stacker while cards are falling into it. You may cause a stacker jam if you do. Stop the unit, unload the stacker, then restart the unit. The time you lose by stopping the unit will be far less than the time required to clear a jam, repunch the information in new cards, and hand file the replacement cards.

Have storage trays at hand for card punch output. One tray can hold 3000 cards.

Label output decks as the run book directs. When a damaged or destroyed card cannot be replaced immediately, mark the location of the missing card with a blank card of a contrasting color or with a piece of paper to facilitate later insertion of a replacement card.

Section 3

OPERATOR'S CONSOLE MODEL 124

3-1. DESCRIPTION

The Operator's Console Model 124 (figure 3-1) contains the controls and indicators used to turn on and operate the system. It consists of a single-pedestal desk that has a control panel and keyboard assembly, a printer, a monitor panel, and an addressable clock. There is a paper compartment under the printer. The clock is in the compartment below the monitor panel.

3-2. Control Panel and Keyboard

Figure 3-2 shows the control panel and keyboard.

Table 3-1 lists and describes the controls and indicators.

3-3. Monitor Panel

Figure 3-3 shows a typical monitor panel. Green indicators show which units are off line; yellow indicators call your attention to units in which a fault has occurred. An indicator on the control panel of the unit shows what fault occurred. When a fault indicator lights on the monitor panel, a buzzer sounds in the power-control cabinet. The pushbutton on the left-hand end of the monitor panel may be used to silence the fault alarm buzzer.

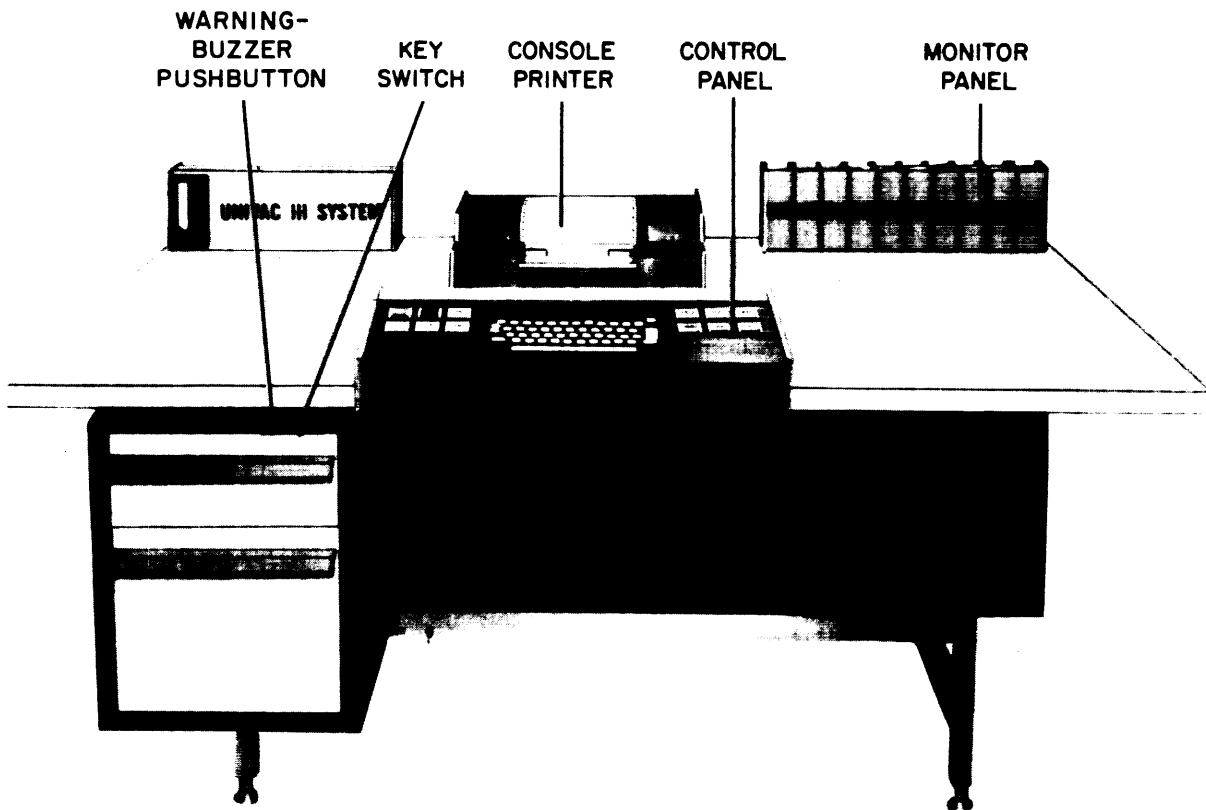
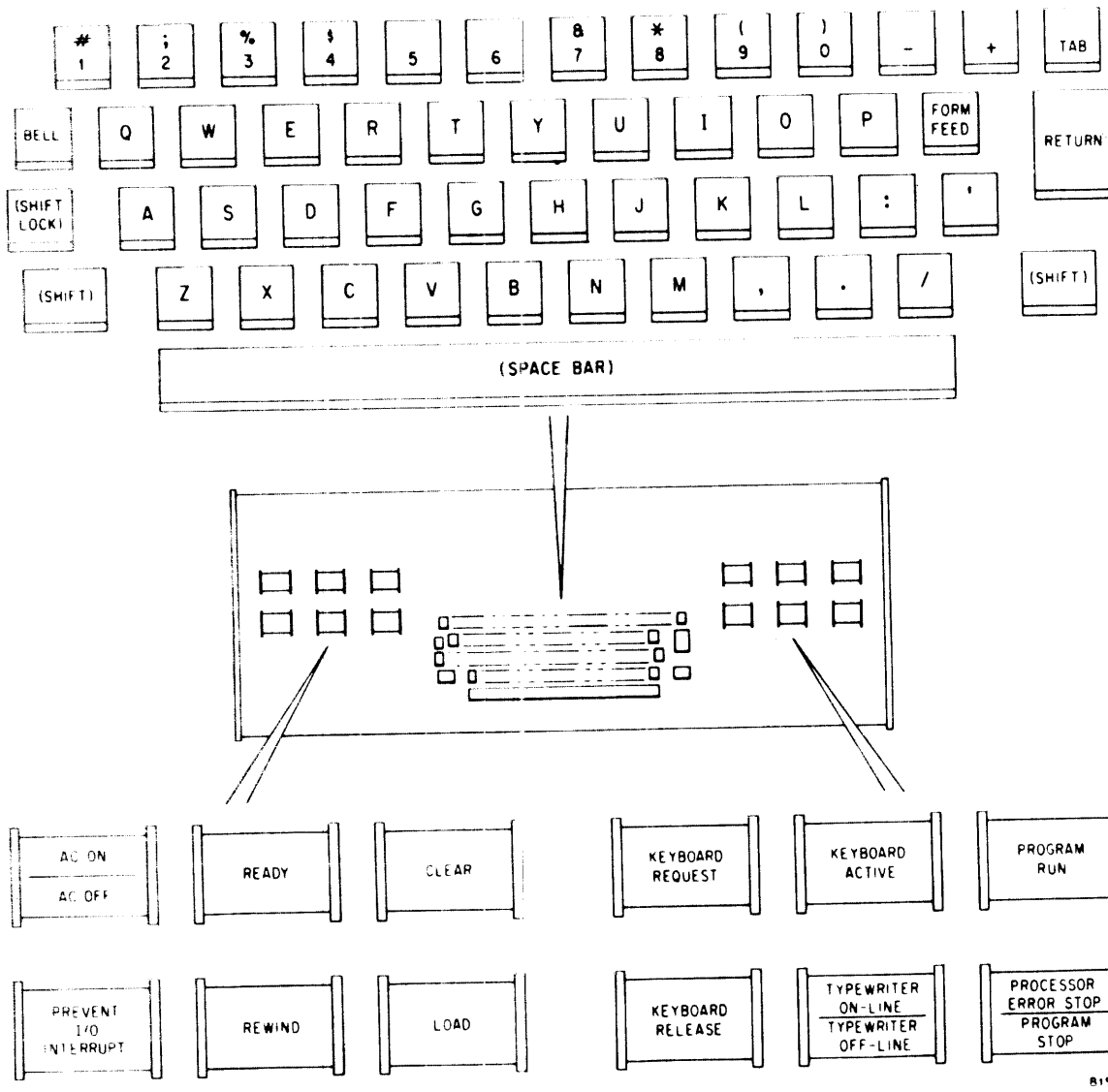

Figure 3-1. Operator's Console Model 124



8192

Figure 3-2. Control Panel and Keyboard, Operator's Console Model 124

Table 3-1. Controls and Indicators, Operator's Console

Legend type is abbreviated as follows:

- S—Pushbutton (switch) only,
- I—Indicator (lamp) only, and
- S/I—Combined pushbutton and indicator.

Pushbutton or Indicator			Function or Indication
Marking	Color	Type	
Key Switch (no marking)	—	Key	When locked in off position, prevents use of any system controls. See figure 3-1.
Warning-Buzzer Pushbutton (no marking)	—	S	Pressing pushbutton sounds warning buzzer. See figure 3-1.

Table 3-1. Controls and Indicators, Operator's Console (cont)

Pushbutton or Indicator			Function or Indication
Marking	Color	Type	
AC ON	Red	S/L	When key switch is on, turns on or turns off system power.
AC OFF	Green		Red half (AC ON) lights when a-c contactors are closed; green half (AC OFF) lights when a-c contactors are open.
READY	Green	L	Indicator lights when all voltages are at operating levels.
CLEAR	White	S	Clears all instruction-control circuits, all error indicators, and all test circuits.
PREVENT I/O INTERRUPT	Blue	L	Indicator lights when Inhibit I/O Interrupt FF is set by PIO (62) instruction.
REWIND	White	S/L	Indicator lights when information on UNISERVO III magnetic tape is read incorrectly. Pressing pushbutton causes logical UNISERVO 0 to rewind tape without interlock.
LOAD	White	S/L	Indicator lights if information on UNISERVO III magnetic tape was not written correctly (bad spot on tape). Pressing pushbutton causes logical UNISERVO 0 to read forward one block. Used for initial loading from tape to memory.
KEYBOARD REQUEST	White	S	Pressing pushbutton connects keyboard to processor input circuits.
KEYBOARD ACTIVE	White	L	Indicator lights to show that keyboard may be used to type. If printer is on line, operator may type information into processor. If printer is off line, keyboard operates printer, but has no other effect of system.
PROGRAM RUN	Green	S/L	Indicator is lit while processor is operating. Pressing pushbutton starts program.

Table 3-1. Controls and Indicators, Operator's Console (cont)

Pushbutton or Indicator			Function or Indication
Marking	Color	Type	
KEYBOARD RELEASE	White	S	Pressing pushbutton disconnects keyboard from processor input circuits.
TYPEWRITER ON-LINE	White	S/L	Indicator shows status of console printer. If console printer is off line, pressing pushbutton places it in on-line status; if printer is on line, pressing pushbutton places it in off-line status.
TYPEWRITER OFF-LINE	Blue		
PROC. ERROR STOP	Red	S/L	PROC. ERROR STOP indicator lights when processor stops because of a second uncorrected error.
PROGRAM STOP			Pressing pushbutton starts operation that causes program to stop processor by executing a WAIT (77) instruction. PROGRAM STOP indicator lights when processor executes WAIT instruction and stops.
Lock-Reset Pushbutton	—	S	Located in clock compartment. Used when turning on system power and after changing clock setting. Refer to headings 3-10 and 3-11.
Buzzer-Override Pushbutton	—	S	Located on left-hand end of monitor panel. Pressing pushbutton silences fault alarm buzzer, but does not extinguish yellow indicator on monitor panel.

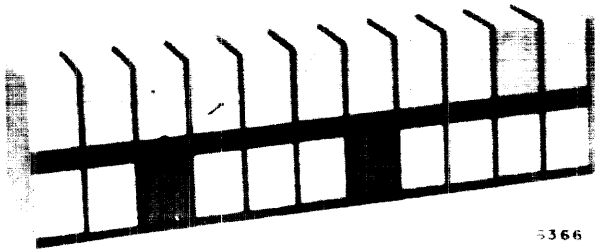

Figure 3-3. Typical Monitor Panel

3-4. Console Printer

The console printer is a Teletype¹ Model 28 printer with a modified type box. The printer is mounted in the upper half of a compartment at the rear of the desk. The lower half of the compartment serves for paper storage. Figures 3-4 and 3-5 show right-rear and front views of the console printer. Information typed at the keyboard is printed on the console printer. When you type from the keyboard, type with a steady, deliberate touch. Too-fast or erratic typing may cause errors by momentarily exceeding, for one character, the response speed of the printer.

¹Trademark of the Teletype Corporation, subsidiary of Western Electric Company, Chicago, Illinois.

3-5. OPERATING PROCEDURES

The remainder of this section gives step-by-step instructions for loading paper, changing ribbon, and cleaning type in the console printer, and it describes what you must do to turn on the system.

3-6. Loading Paper

To load paper in the console printer (figure 3-4), perform the following steps:

- (1) Put printer in off-line status.
- (2) Open printer cover and printer-compartment door.
- (3) Place box of paper in paper compartment, and pull free end up and over loading plate.
- (4) Pull paper-release lever toward rear of typewriter to release paper fingers.
- (5) Hold paper against right-hand side of loading plate (side toward platen handwheel) and push it under platen.

- (6) Push platen handwheel down to engage it, and turn handwheel to feed paper around platen. Guide paper between paper fingers and platen.
- (7) Push paper fingers down, against paper, and turn platen handwheel to feed out one complete page.
- (8) Adjust paper to have first line of typing about 1 inch below a fold.
- (9) Pull out the index wheel and turn it counter-clockwise to set white index line at pointer.

CAUTION

Be sure the ribbon (heading 3-7) and the type-box latch (heading 3-9) are in the proper position.

- (10) Close typewriter cover and door.
- (11) Open transparent access plate, pull out free end of paper, then close access plate.

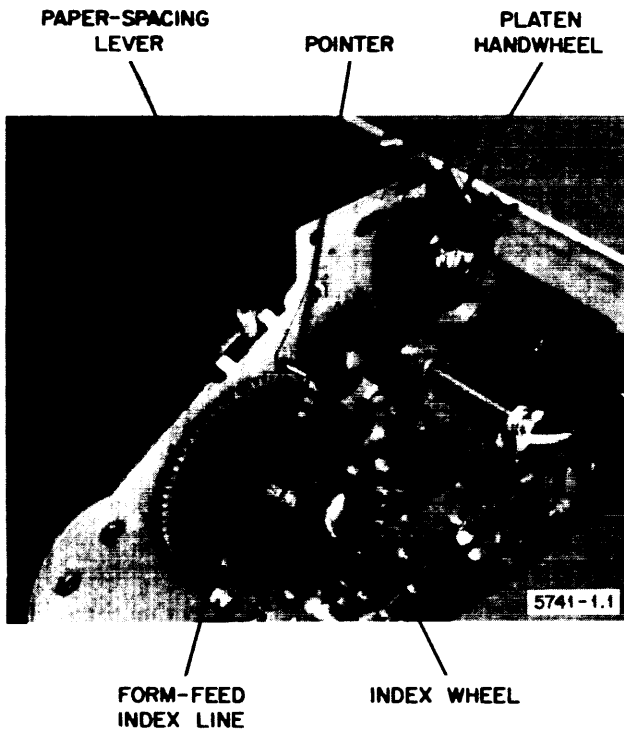

Figure 3-4. Console Printer, Rear View

3-7. Changing Ribbon

To change the console printer ribbon, perform the following steps:

- (1) Put printer in off-line status.
- (2) Open printer cover.
- (3) Release spool locks and lift out both spools (figure 3-5).
- (4) Disengage ribbon from rollers, reverse levers, and ribbon guides.
- (5) Empty one spool and hook end of new ribbon to hub. Wind ribbon onto spool until reversing eyelet is wound onto spool.
- (6) Replace spools on shafts and lock them in place. Be sure ribbon is not twisted.
- (7) Thread ribbon around rollers and through reverse levers and guides. Turn free spool to take up slack.
- (8) Be sure reversing eyelet is between spool and reversing lever, and that type-box latch has not been released, then press FORM FEED key to bring clean paper under ribbon.
- (9) Close printer cover and adjust paper.

3-8. Cleaning Type

If the printing becomes blurred, remove the type box (heading 3-9) and clean it by brushing with a dry, stiff-bristled brush. Hold the type box over a sheet of paper to catch the dirt. Do not use type cleaner or any other solvent; solvents may carry dirt into the type box between the type pallets or may remove the film of oil from the assembly. Solvent that soaks into the assembly may be slow to dry and may damage the ribbon.

Another way to clean the type box is to use a dough eraser. Push the eraser into the type; dirt in the type will stick to the eraser. To clean out small spaces, knead the eraser to a sharp point and push the point into the space you want to clean.

3-9. Removing and Replacing Type Box

To remove the type box from the console printer for cleaning, put the printer in the off-line status and open the printer cover; then proceed as follows:

- (1) Push type-box latch to your right to unlock it (figure 3-6).
- (2) Remove type box from the carriage by pulling upward and to your left the small handle on right-hand end of type box.

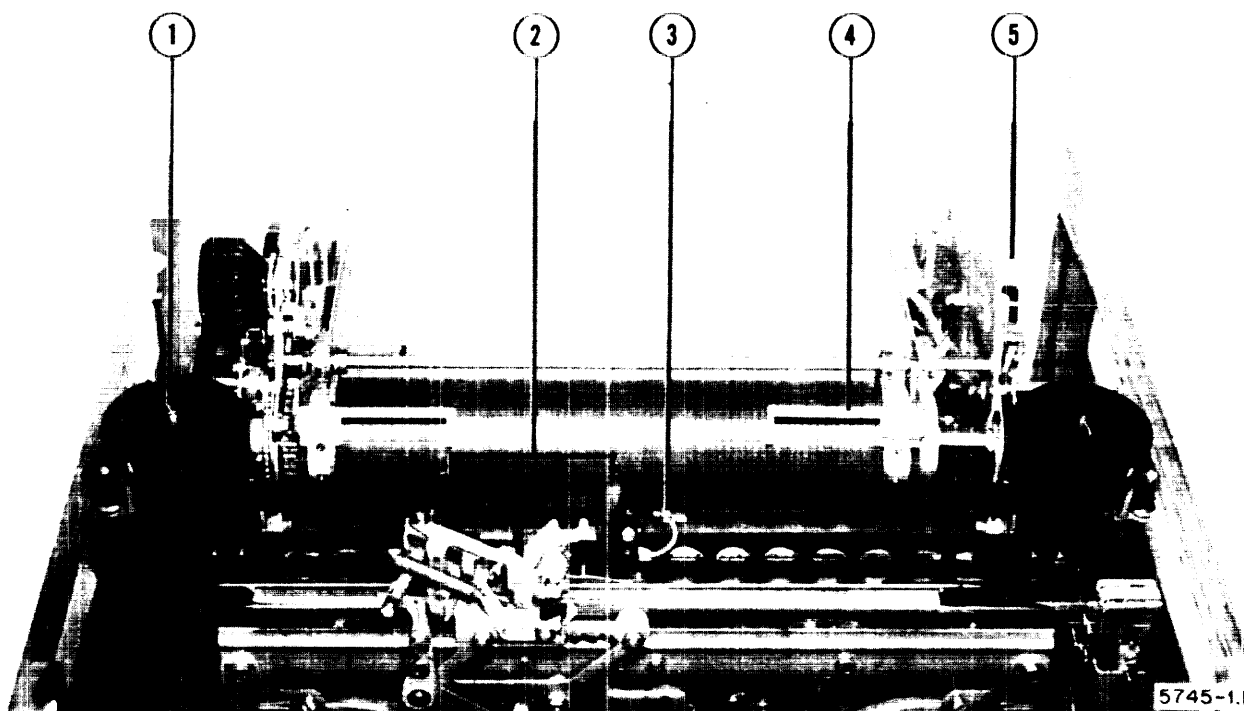

- | | | |
|----------------------|-------------------|-------------------------------|
| 1. Ribbon-Spool Lock | 3. Type-Box Latch | 5. Paper-Finger Release Lever |
| 2. Ribbon Guides | 4. Paper Finger | |

Figure 3-5. Console Printer, Front View

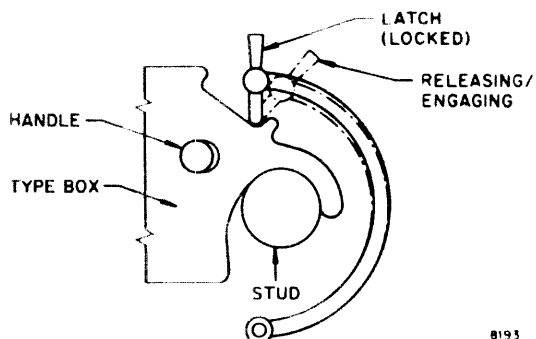

Figure 3-6. Type-Box Latch Operation

To replace the type box, perform the following steps:

- (1) With type toward the ribbon, and LTRS and FIGS arrows up, engage the hook at left-hand end of type box under the stud of the left-hand type-box roller.
- (2) Place the hook on the right-hand end of the type box over the stud of the right-hand type-box roller, and press on the FIGS pointer to push the type box into place.
- (3) Hold the type-box latch in the horizontal position, move it to your left to engage the latching notch, and raise the latch to lock the type box in place.

(4) Be sure the ribbon is properly threaded, then close the printer cover.

3-10. Turning On the System

To turn on the system, carry out the following procedure:

- (1) Turn on key switch (figure 3-1). Green half (AC OFF) of power indicator on control panel should light.
- (2) Push warning-buzzer pushbutton (figure 3-1) to warn anyone who is working on system equipment that you are about to turn on power.
- (3) Push AC ON/AC OFF pushbutton. Red half (AC ON) of power indicator should light; green half should extinguish.
- (4) Observe monitor panel. If any yellow indicator lights, take whatever corrective action is needed.
- (5) Verify setting of addressable clock. If setting is incorrect, set clock. Whenever you turn on system power, push clock-reset pushbutton (figure 3-7).

3-11. Setting Addressable Clock

WARNING

There are exposed electrical connections in the clock compartment.

To set the addressable clock (figure 3-7), turn the knurled inner knob clockwise to set the minute hand, and turn the outer knob clockwise to set the hour hand. Note that the hour scale (the outer scale) is a 24-hour scale and that the hour hand is the longer black hand.

When you have set the clock hands, push the clock-reset pushbutton.

3-12. Interchanging Console Printers

If the console printer should fail, it may be disconnected and removed from the console, and another printer may be installed, without tools. To exchange printers, perform the following operations:

CAUTION

The printer weighs approximately 35 pounds. Do not attempt this procedure unless you are certain you can manage without risk either to yourself or to the printer. If in doubt, call your supervisor or the customer engineer.

- (1) Turn off system power.
- (2) Open printer-compartment door and printer cover. Tear off the paper at loading plate, and remove paper supply from paper compartment.
- (3) Disconnect three printer cable connectors (figures 3-7 and 3-8).
- (4) Slide out drip pan and unlock and remove four quarter-turn fasteners from below printer chassis.
- (5) Carefully pull printer to rear until friction catches at front of the chassis release.
- (6) Slide printer to rear and lift it out.
- (7) Slide replacement printer into position, and push until friction catches engage.

- (8) Connect cables, reload paper, and close cover and door.
- (9) Turn on system power.

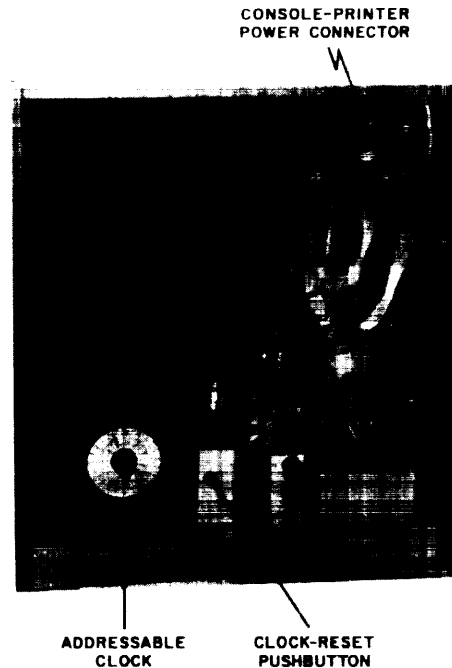

Figure 3-7. Addressable Clock

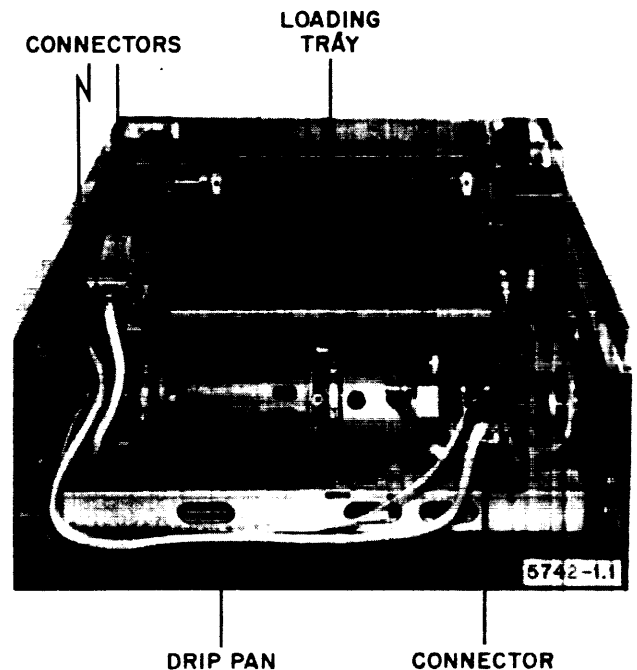

Figure 3-8. Console-Printer Connectors

Section 4

UNISERVO III MAGNETIC-TAPE UNIT MODEL 126

4-1. DESCRIPTION

The UNISERVO III Magnetic-Tape Unit Model 126 (figure 4-1) is the principal tape-handling, reading, and writing device of the UNIVAC III system. A system may use up to 32 UNISERVO III tape units for data input and output, and for auxiliary memory. The system program controls the operation of the tape units through UNISERVO III synchronizers; each synchronizer controls the detailed operation of up to 16 tape units.

A tape unit moves tape forward or backward past the read-write heads and rewinds the tape on commands from the system. (Tape is said to be moving forward when it is moving from the supply reel to the takeup reel.) The tape unit may read information from the tape while the tape is moving in either direction. Write operations may occur only during forward tape movement.

UNISERVO III tape units use 1/2-inch wide Mylar base, oxide coated, magnetic tape. Refer to section 2 for a more detailed description of the tape and reel dimensions and weights.

Figure 4-2 shows the tape panel and control panel of a UNISERVO III Magnetic-Tape Unit Model 126. Figure 4-3 is a detailed view of the control panel. Table 4-1 lists the controls and indicators on the tape-unit control panel and gives a brief description of the function of each. Table 4-2 lists and describes additional controls and devices relevant to your duties.

4-2. Tape-Transport System

The tape-transport system moves tape forward or backward past the read-write head. Tape speed during reading and writing operations is 100 inches per second. During a rewind operation, tape speed is 150 inches per second; a full 2400-foot reel of tape can be rewound in less than 3-1/4 minutes.

The tape-transport system consists of a vacuum-assisted capstan, two reversible reel motors with fast-acting brakes, tape-loop columns that hold

loops of tape under vacuum tension, reel-motor control circuits that control loop size and balance, and protective devices. Figure 4-2 shows the external components of the tape-transport system. Table 4-3 lists the protective devices and briefly describes the function of each device.

4-3. Position Detection

The tape-transport system includes circuits that detect reference points on the tape to position the tape at the proper starting point, to warn the system that the end of the tape is approaching, and to prevent pulling the tape completely off either reel.

Transparent windows, prepared by scraping the oxide coating from the transparent tape base, mark the starting (load) point and end-of-tape warning point. The last 20 feet of tape are transparent and serve as an end-of-tape indicator for forward operation. The reel end of the takeup leader is transparent and is the end-of-tape indicator when the tape has been completely rewound. Photocell assemblies detect the transparent areas; a detector assembly (figure 4-2) near the read-write head assembly detects the load-point and end-of-tape warning windows, and two detector assemblies (figure 4-2) detect the end-of-tape points.

4-4. Read-Write Circuits

The read-write circuits are the information-transfer path between the system and the magnetic tape. Electronic switches under system control connect the read-write head of a selected tape unit to a data-transfer circuit (bus) shared by a group of tape units. The reading and writing circuits read information from and write information on magnetic tape as it moves past the read-write head. A UNISERVO III read-write head is actually two heads, a read head and a write head spaced 1/4 inch apart in one head assembly. Tape moving forward passes the read head after it has passed the write head. This arrangement enables the system to verify information as it is recorded.

If the read circuits detect an error during a write operation, the system immediately writes a distinctive pattern following the incorrect information and,

under program control, repeats the write operation. If the read circuits detect the bad-spot pattern during a read operation, the system disregards the

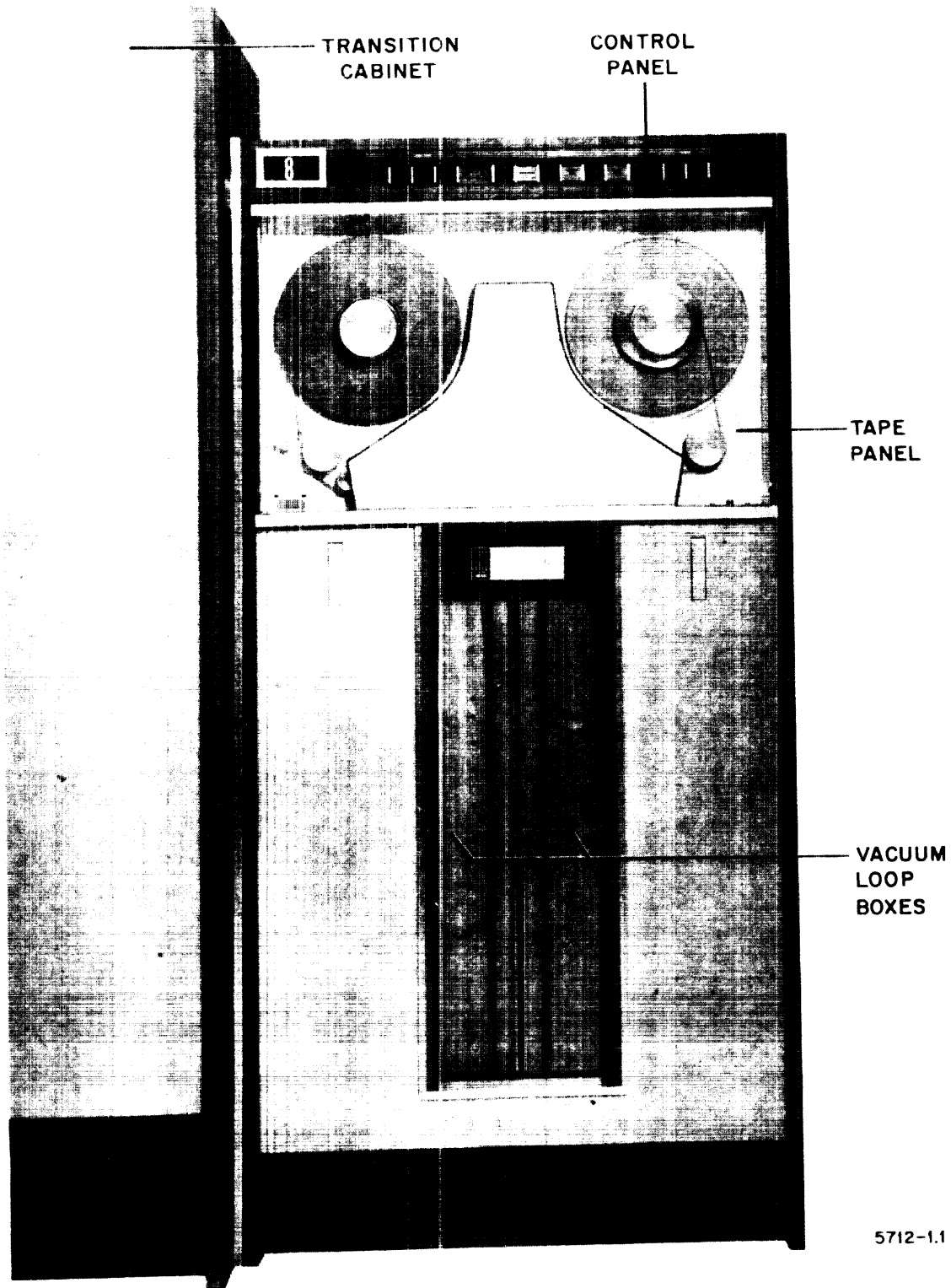
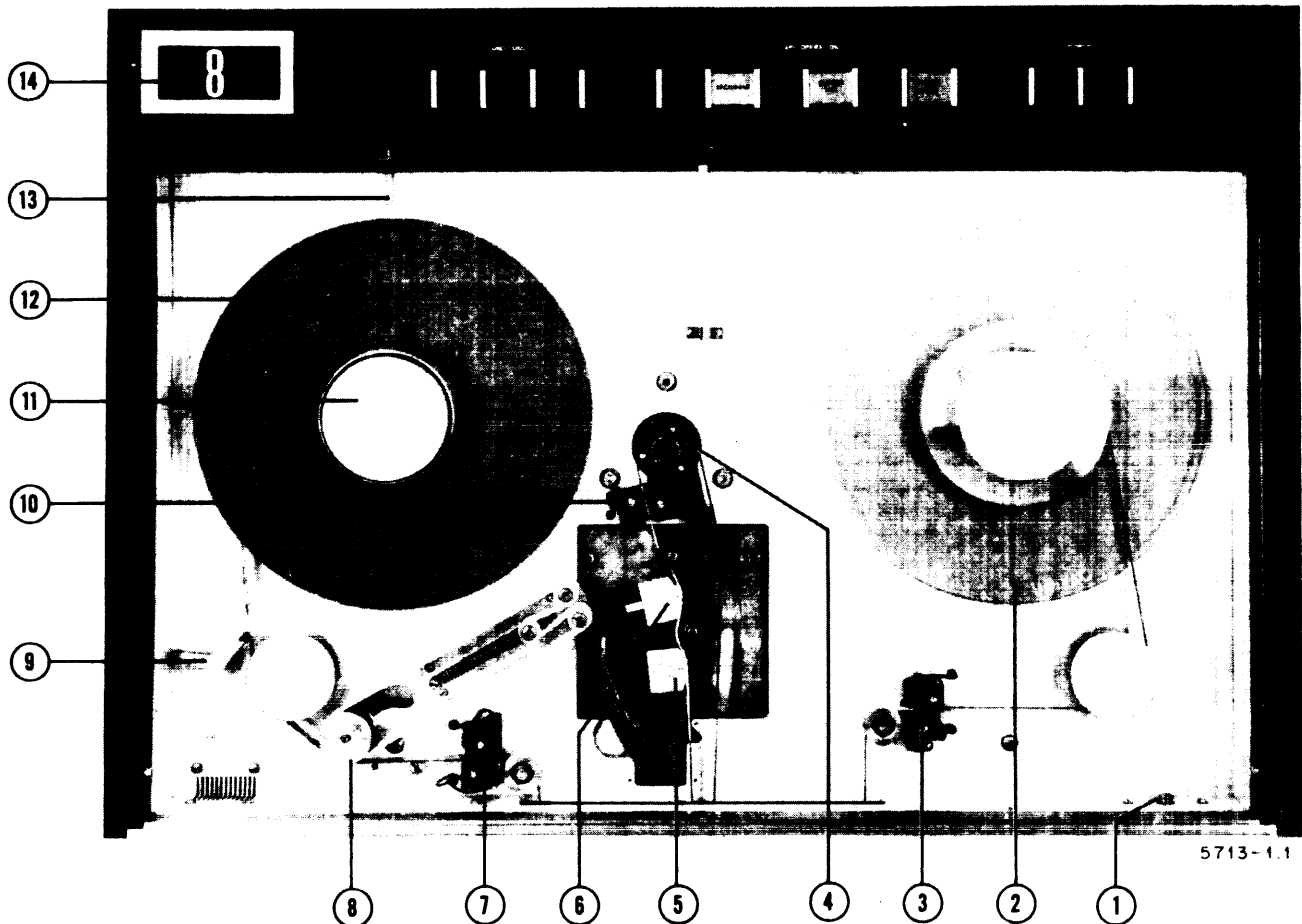

Figure 4-1. UNISERVO III Magnetic-Tape Unit Model 126 and Transition Cabinet

incorrect information preceding the bad-spot pattern and reads the next block of information, which contains the same information written correctly. An

erase head (figure 4-2) erases all information from sections of tape that are to be used immediately for recording new data.



- | | | |
|-----------------------------|---|---------------------------|
| 1. Manual-Run Switch | 6. Read-Write Head | 11. Supply-Reel Hub |
| 2. Takeup Reel | 7. Forward-Limit Photocell | 12. Supply Reel |
| 3. Backward-Limit Photocell | 8. Tape-Wiper Drive Roller | 13. Door-Interlock Switch |
| 4. Capstan | 9. Tape Clamp | 14. Unit Numeral Block |
| 5. Erase Head | 10. Load-Point and End-of-Tape Warning Photocells | |

Figure 4-2. UNISERVO III Tape Panel and Control Panel

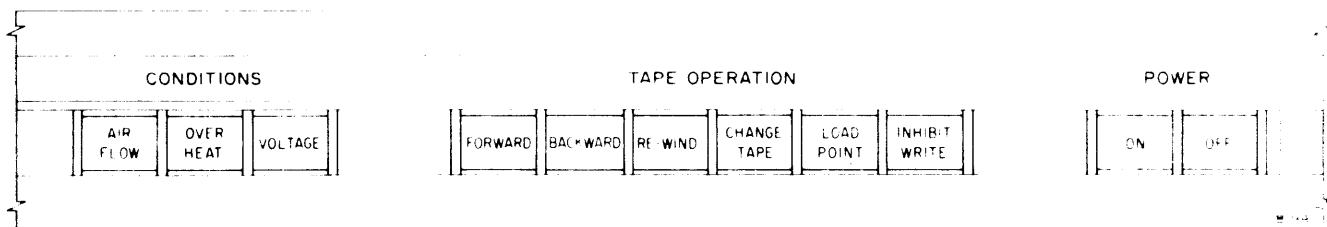

Figure 4-3. UNISERVO III Tape-Unit Control Panel

Table 4-1. Control Panel, UNISERVO III Magnetic-Tape Unit Model 126

Component type is abbreviated as follows:

- S—Pushbutton (switch) only,
- I—Indicator (lamp) only, and
- S/L—Combined pushbutton and indicator.

Pushbutton or Indicator			Function or Indication
Marking (Unit Numeral)	Color	Type	
	Red or White	L	Indicator lights red when tape unit is on, but tape panel door is open. Lights white when unit is operating, or ready to operate, under system control. Numeral blocks are interchangeable.
CONDITIONS			
AIR FLOW	Red	L	Indicator lights when air flow failure has occurred. The d-c power is off.
OVERHEAT	Red	L	Indicator lights when cabinet temperature has exceeded 130°F. The d-c power is off.
VOLTAGE	Red	L	Indicator lights when a circuit breaker is open.
TAPE OPERATION			
FORWARD	Green	S/L	Indicator lights when unit is set for forward operation or is running forward. Pressing pushbutton sets unit for forward operation.
BACKWARD	Green	S/L	Indicator lights when unit is set for backward operation or is running backward. Pressing pushbutton sets unit for backward operation.
REWIND	Blue	S/L	Indicator lights when rewind operation is in progress. When unit is set for backward operation, pressing pushbutton starts rewind operation with interlock against further system-controlled operation. (Lights CHANGE TAPE indicator.)
CHANGE TAPE	Yellow	S/L	Indicator lights when rewind interlock is in effect; operator intervention required to return unit to system control. Pressing pushbutton removes rewind interlock and, if door is closed, advances tape to load point.

Table 4-1. Control Panel, UNISERVO III Magnetic-Tape Unit Model 126 (cont)

Pushbutton or Indicator			Function or Indication
Marking	Color	Type	
LOAD POINT	Blue	L	Indicator lights when tape is in first-block position.
INHIBIT WRITE	Yellow	L	Indicator lights when tape reel on unit does not contain write-enable ring, or when no reel is mounted.
POWER			
ON	Green	S/L	Indicator lights when power turn-on sequence is complete; unit is ready to operate. Pressing pushbutton starts power turn-on sequence in unit.
OFF	Red	S/L	Indicator lights when a-c power is on and d-c power is off. Pressing pushbutton turns off d-c power in unit.

Table 4-2. Tape-Panel Controls and Devices, UNISERVO III Tape Unit

Device	Location	Function
Manual-Run Switch	See figure 4-2	Starts or stops tape-transport system for manually-controlled tape transport, either forward or backward.
Tape Clamp	See figure 4-2	When tape unit is off and tape-panel door is open, fully engaged position clamps leader and releases reel brakes; fully released position locks reel brakes.

4-5. File Protection

The erasing and writing circuits are normally disconnected. To connect these circuits, you must insert a plastic ring in the rear face of the supply reel. The ring operates switches that connect the circuits. To protect a master file, remove the ring (if there is one in the reel). A reel without a ring allows the circuits to remain disconnected, thereby protecting the contents of the file on that reel. The INHIBIT

WRITE indicator on the tape-unit control panel is lighted unless a reel containing a write-enable ring is mounted on the tape unit.

Table 4-3. Protective Devices, UNISERVO III Tape Unit

Device	Location	Function
Door-Interlock Switch	See figure 4-2	When tape unit is on, disconnects tape-transport mechanism from system control when tape-panel door is opened, and causes unit numeral to light red.
Loop-Limit Switches	In cabinet	Stop tape unit if either loop rises above or drops below sensing ports or if the tape breaks.
Thermostatic Switches	In cabinet	Turn off tape unit if cabinet temperature exceeds 130°F.
Tape-Limit Photocells	See figure 4-2	Stop tape at marked limit points. Prevent pulling tape completely off reels.

4-6. OPERATING PROCEDURES

The operating procedures and tasks listed or described in the following paragraphs are those you must perform at the tape unit or at the transition cabinet. The following paragraphs describe the procedures for daily preparation of the unit, tape loading and changing, changing the tape wiper, and changing the logical designation of a tape unit.

4-7. Preparation: Daily Inspection

Inspect each tape unit daily, prior to using it for the day's run. If there is any unsatisfactory condition, notify your supervisor or the customer engineer. If possible, substitute a spare tape unit (heading 4-11) for a unit that requires maintenance. Prepare and inspect each tape unit (with a-c power on) as follows:

- (1) Clean heads and tape guides by wiping with finger. Be sure your finger is clean and dry.
- (2) Look at tape wiper. Replace when less than 1/8 inch of clean surface remains.
- (3) Examine tape-unit leader for wear, scratches, rough or wrinkled edges.
- (4) Observe all photocell exciter lamps. Notify customer engineer if any exciter lamp does not light.
- (5) Observe control-panel indicators for dark spots, which indicate defective lamps. Notify customer engineer if any indicator shows a dark spot, but this condition alone is not cause for taking unit off line.
- (6) Inspect tape clamps for worn or missing pads.
- (7) Test reel-brake release switch by locking tape clamp. Reel brakes should release to enable tape reels to be turned by hand.
- (8) Inspect vacuum-loop boxes for dirt, fragments of tape, or other foreign matter.

4-8. Loading Tape

To load tape on a UNISERVO III tape unit, follow the instructions given in the Procedure column of table 4-4, and illustrated in figures 4-4 and 4-5. If indications shown in Remarks column do not occur, notify customer engineer.

4-9. Changing Tapes

A rewind-with-interlock instruction starts a rewind operation and lights the BACKWARD, REWIND, and

CHANGE TAPE indicators. The BACKWARD and REWIND indicators are extinguished at the end of the rewind operation, but the CHANGE TAPE indicator remains lit. The tape unit will not operate under system control until the operator clears the interlock, either by turning off the unit or by pushing the CHANGE TAPE button.

NOTE

Pushing the CHANGE TAPE button without first turning the unit off or opening the tape-panel door will cause the unit to advance the tape to the load point.

Table 4-4. Tape-Loading Procedure, UNISERVO III Tape Unit

Step	Procedure	Remarks
1	If the ON indicator is lighted, push the OFF pushbutton.	Extinguishes ON indicator and CHANGE TAPE indicator, lights OFF indicator.
2	Unlock and lower the tape-panel door. Lock it in the open position.	
3	Examine the reel to be loaded for proper winding (oxide in or oxide out, as required), and write-enable ring if required.	Remove retaining band.
4	Push the reel, label-side out, onto the supply-reel hub. (Press near the hub.) Push until the reel latches securely in place.	See figure 4-4. If reel does not contain a write-enable ring, INHIBIT WRITE indicator remains lighted.
5	Rotate the supply reel to unreel a convenient length of leader.	
6	Inspect the leader connectors and push the two together. A quarter turn engages the connectors; pull gently to lock. Be sure the tape is not twisted.	See figure 4-5.
7	Release the tape clamp.	
8	Close tape-panel door.	
9	Push the ON pushbutton.	OFF indicator extinguishes, ON indicator lights, vacuum pulls tape taut, unit numeral lights white.

To change a tape on a tape unit that has a rewind interlock in effect, follow the instructions in the Procedure column of table 4-5.

Table 4-5. Tape-Changing Procedure, UNISERVO III Tape Unit

Step	Procedure	Remarks
1	Push the OFF pushbutton.	CHANGE TAPE and ON indicators extinguish. OFF indicator lights.
2	Open the tape-panel door, bring the tape connector to a convenient position, and clamp the leader.	Refer to table 4-2.
3	Disconnect the tape from the leader.	
4	Grasp the reel lightly by the edges with your fingertips. Press the reel-release button with your thumbs until the reel slides off the hub.	See figure 4-6.
5	Remove the reel, mark it, and load the next reel.	Refer to table 4-4. Use elastic band to maintain proper winding tension.



Figure 4-4. Mounting Supply Reel



Figure 4-5. Connecting Leaders, Plastic Leader/Connector



Figure 4-6. Releasing Supply Reel

4-10. Changing Tape Wiper

To change a tape wiper, turn off the unit, open the tape-path shield, and proceed as follows:

- (1) Grasp cloth belt as shown in figure 4-7, and pull both sides in direction shown.
- (2) Release belt from drive roller, allow tension spring to retract, and remove belt from wiper assembly.

(3) Thread clean belt on tension rollers, stretch tension spring as in step 1, and slip new belt around drive roller. Be sure nap side of belt is out. Align belt on drive roller.

CAUTION

The drive roller turns in a counterclockwise direction. Do not try to turn it clockwise when aligning the belt.

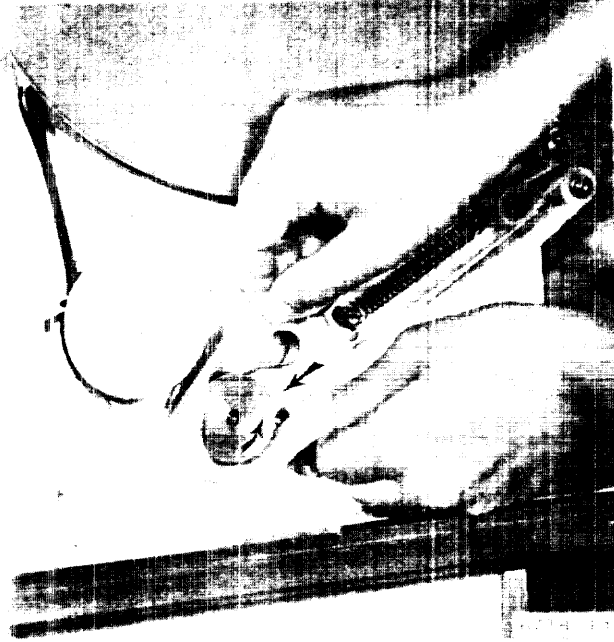

Figure 4-7. Changing Tape Wiper

4.21 Exchanging Tape Units

Each tape unit requires two coincident control signals to start any operation. An operation-control signal is applied to corresponding control elements in all tape units in the same group. The second signal, a tape-unit select signal, designates the tape unit which is to respond and is applied to all control elements in that unit.

The UNISERVO III tape-unit-select patch panel in the transition cabinet (figure 4-8) provides the facility to select a particular tape unit for operation. At the top of the patch panel are two connection blocks. Each connection block contains up to eight receptacles (0-7 and 8-15). Each receptacle is connected to a tape unit. Up to 16 cords (0-7 and 8-15), fixed at the lower end, plug into the receptacles at the top

of the panel. These cords are the select signal lines from the UNISERVO synchronizer in the processor; the number of each cord is the logical number used by the system to specify an individual tape unit in a given group.

You may designate any tape unit in the same group of tape units by any logical number available at the patch panel by plugging the appropriate select signal line into the desired receptacle at the top of the panel. For example, the third tape unit in a line of tape units may be designated logical unit 0 by connecting the select-signal line 0 to tape-unit receptacle 2 at the top of the panel. All signals that appear on select-signal line 0 will be applied to the third tape unit.

Whenever you change the logical designation of a tape unit, change the unit numeral block (figure 4-2) to correspond to the patch-panel change. To remove a numeral block, pull it straight out; to replace it, push it straight into the panel opening.

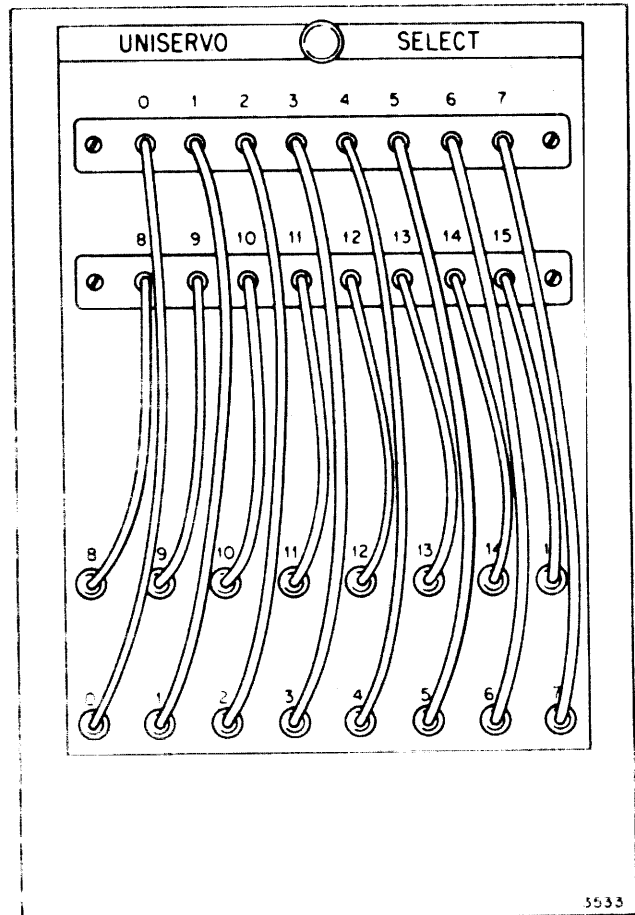

Figure 4-8. UNISERVO III Tape-Unit-Select Patch Panel

Section 5

UNISERVO IIA MAGNETIC-TAPE UNIT MODEL 72

5-1. DESCRIPTION

The UNISERVO IIA Magnetic-Tape Unit Model 72 (figure 5-1) is a tape-handling, reading, and writing device. It is used with the UNIVAC III Data-Processing System to provide input-output compatibility with other data-processing systems, and to provide a direct magnetic-tape input facility through tapes prepared on the UNITYPER II magnetic-tape typewriter or the UNIVAC Input Verifier. A UNIVAC III system may use up to six UNISERVO IIA tape units. The system controls the operation of the tape units through the UNISERVO IIA tape-unit synchronizer.

A tape unit moves tape forward or backward past the read-write head, and rewinds the tape on command from the system. (Tape is said to be moving forward when it is moving from the supply reel to the takeup reel.) The tape unit may read information from the tape when the tape is moving in either direction. Write operations may occur only during forward tape movement.

UNISERVO IIA tape units use either oxide-coated 1/2-inch wide Mylar plastic or magnetic-alloy plated 1/2-inch metal tape. Refer to section 2 for a more detailed description of tape and reel dimensions and weights.

Figure 5-2 shows a UNISERVO IIA tape panel and control panel. Figure 5-3 is a detailed view of the control panel. Table 5-1 lists the controls and indicators on the tape-unit control panel and gives a brief description of each. Table 5-2 lists and describes additional controls and indicators that you must use.

5-2. Tape-Transport System

The tape-transport system moves tape forward or backward past the read-write head. Tape speed is 100 inches per second.

The tape-transport system consists of a capstan, two reversible reel motors with fast-acting brakes, tape-loop columns that hold loops of tape under

vacuum tension, reel-motor control circuits that control loop size and balance, and protective devices. Figure 5-2 shows the tape panel, which contains the external components of the tape-transport system. Table 5-3 lists the protective devices and briefly describes the function of each device.

5-3. Position Detection

The tape-transport system includes devices and circuits that detect reference points on the tape or leader to position the tape at the proper starting (first-block) point and to prevent pulling the tape completely off either reel.

Rubber treads cemented to the tape leaders mark the end-of-tape points on both metal and plastic tapes used on UNISERVO IIA tape units. Snap-action switches, actuated by sensing arms, stop the unit when the treads pass between either sensing arm and the idler pulley. The switches disable the tape-transport assembly until you manually wind the tape and treads back past the tripped sensing arm, except after a rewind operation. The first-block point is detected electronically when the read circuits sense the first block of information written on the tape.

Some plastic tapes used on UNISERVO IIA tape units do not have rubber treads: to sense the forward limit point on these tapes, a forward-limit photocell assembly senses the transparent portion of the supply-reel leader.

5-4. Read-Write Circuits

The read-write circuits are the information-transfer path between the system and the magnetic tape. Electronic switches under system control connect the read-write head of a selected tape unit to a data-transfer circuit (bus) shared by a group of tape units.

The reading and writing circuits read information from or write information on either metal or plastic magnetic-recording tape as it moves past the read-write head assembly. Relays in the cabinet switch

the head assembly between the read-signal lines and the write-signal lines. A tape-selector switch enables

the operator to adjust the recording circuits to the requirements of the tape in use, and lights one of

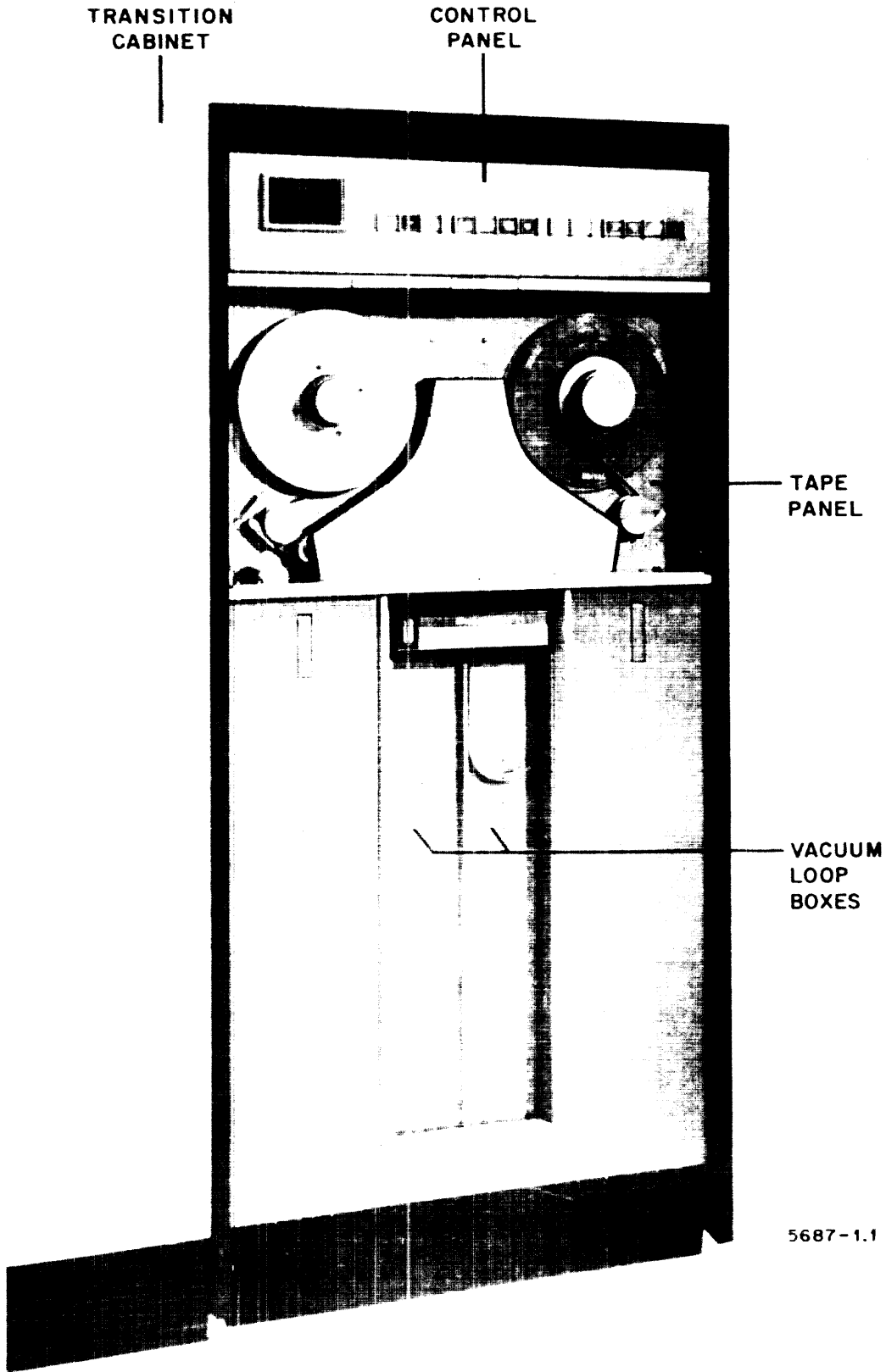

5687-1.1

Figure 5-1. UNISERVO IIA Magnetic-Tape Unit Model 72 and Transition Cabinet

two indicators on the tape-unit control panel. An erase head erases all information from sections of

the tape that are to be used immediately for recording new data.

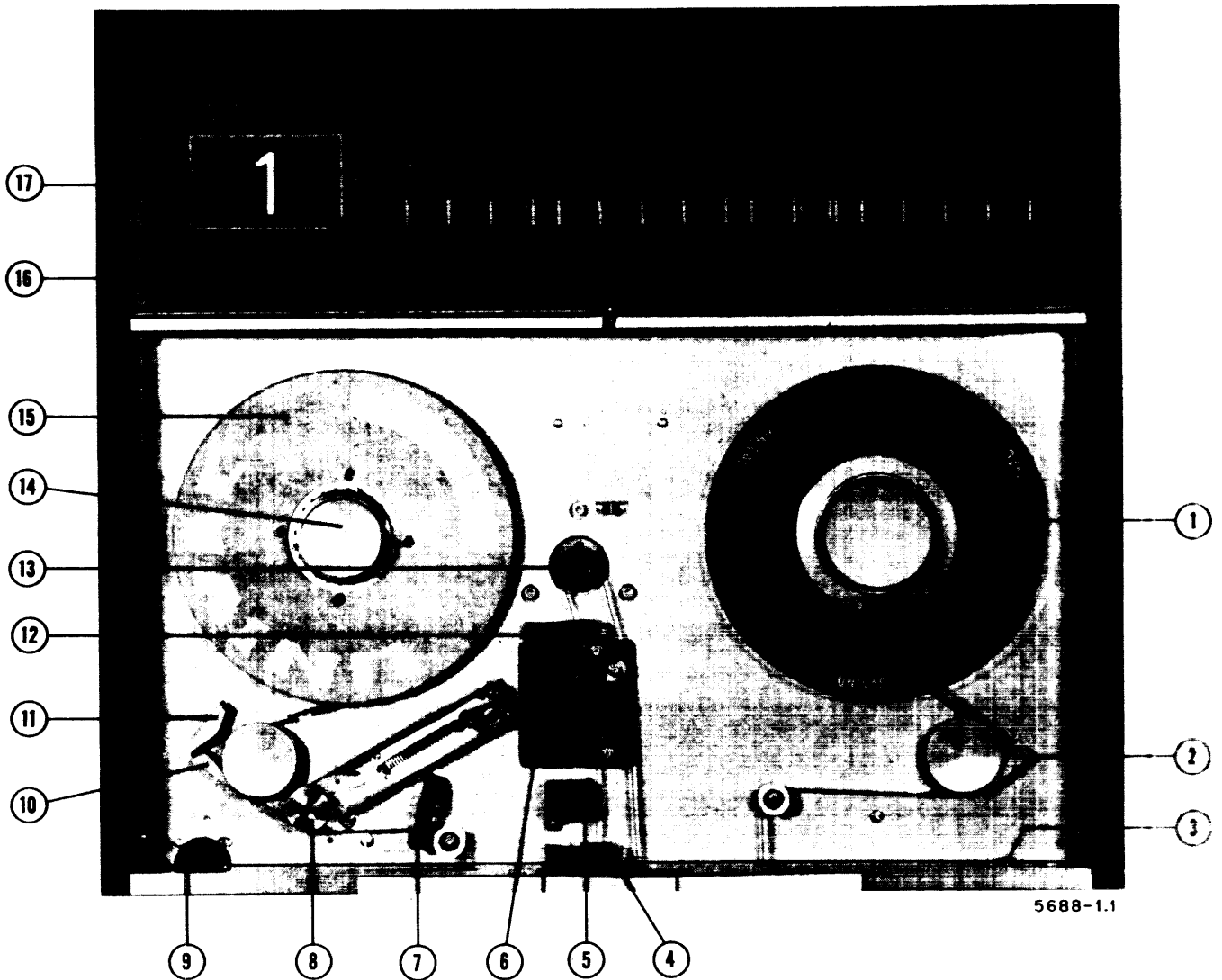

- | | |
|----------------------------|---------------------------|
| 1. Takeup Reel | 10. Forward-Limit Switch |
| 2. Backward-Limit Switch | 11. Tape Clamp |
| 3. Manual-Run Switch | 12. Bad-Spot Photocell |
| 4. Bad-Spot Photocell | 13. Capstan |
| 5. Erase Head | 14. Supply-Reel Hub |
| 6. Read-Write Head | 15. Supply Reel |
| 7. Forward-Limit Photocell | 16. Door-Interlock Switch |
| 8. Tape-Wiper Drive Roller | 17. Unit Numeral Block |
| 9. Tape-Selector Switch | |

Figure 5-2. UNISERVO IIA Tape Panel and Control Panel

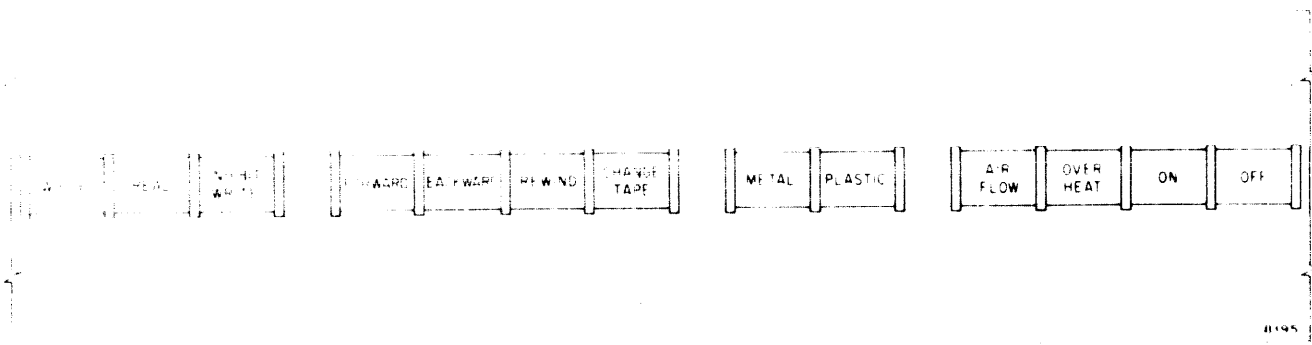

Figure 5-3. UNISERVO IIA Tape-Unit Control Panel

Table 5-1. Control Panel, UNISERVO IIA Magnetic Tape Unit Model 72

Component type is abbreviated as follows:

- S - Pushbutton (switch) only,
- I - Indicator (lamp) only, and
- S/I - Combined pushbutton and indicator.

Pushbutton or Indicator			Function or Indication
Marking	Color	Type	
(Unit Numeral)	Red or White	L	Indicator lights red when tape unit is on, but tape-panel door is open. Lights white when unit is operating, or is ready to operate, under system control.
WRITE	Yellow	L	Indicator lights during write operation.
READ	Green	L	Indicator lights during read operation.
INHIBIT	Yellow	L	Indicator lights when tape reel on tape unit contains file-protection ring.
FORWARD	Green	S/L	Indicator lights when unit is set for forward operation, or is running forward. Pressing pushbutton sets unit for forward operation.
REVERSE	Yellow	S/L	Indicator lights when unit is set for backward operation, or is running backward. Pressing pushbutton sets unit for backward operation.

Table 5-1. Control Panel, UNISERVO IIA Magnetic-Tape Unit Model 72 (cont)

Pushbutton or Indicator			Function or Indication
Marking	Color	Type	
REWIND	Red	S/L	Indicator lights when rewind operation is in progress. When unit is set for backward operation, pressing pushbutton starts rewind operation.
CHANGE TAPE	Red	S/L	Indicator lights when rewind interlock is in effect; operator intervention required to return unit to system control. Pressing pushbutton clears direction-control and rewind circuits, but does not extinguish indicator.
METAL	Green	L	Indicator lights when tape-selector switch is set for metal tape.
PLASTIC	White	L	Indicator lights when tape-selector switch is set for plastic tape.
AIR FLOW	Red	L	Indicator lights when air flow failure has occurred. The d-c power is off.
OVERHEAT	Red	L	Indicator lights when temperature in cabinet has exceeded 130°F. The d-c power is off.
ON	Green	S/L	Indicator lights when power turn-on sequence is complete; unit is ready to operate. Pressing pushbutton starts power turn-on sequence in unit.
OFF	Red	S/L	Indicator lights when a-c power is on and d-c power is off. Pressing pushbutton turns off d-c power in unit.

5-5. File Protection

A metal file-protection ring inserted in the inner diameter at the rear of the reel protects the contents of the tape from erasure; the ring operates switches

in the reel hub to (1) disconnect the write and erase circuits of that tape unit, and (2) to light an indicator on the tape-unit control panel. File-protection rings are used in master-instruction and master-data tape reels.

Table 5-2. Tape-Panel Controls and Devices, UNISERVO IIA Tape Unit

Device	Location	Function
Manual-Run Switch	See figure 5-2	Starts or stops tape-transport system for manually-controlled tape transport, either forward or backward.
Tape-Selector Switch (METAL-PLASTIC)	See figure 5-2	Sets write circuits for writing level appropriate to the tape in use. Adjusts vacuum to proper level for tape in use. Lights indicator on control panel (table 5-1) to show setting of switch.

Table 5-3. Protective Devices, UNISERVO IIA Tape Unit

Device	Location	Function
Door-Interlock Switch	See figure 5-2	Disconnects tape-transport mechanism from system control when tape-panel door is opened, and causes unit numeral to light red.
Loop-Limit Switches	In cabinet	Stop tape unit if either loop rises above or drops below sensing ports in vacuum columns, or if the tape breaks.
Thermostatic Switches	In cabinet	Turn off tape unit if cabinet temperature exceeds 130°F.
Tape-Limit Switches	See figure 5-2	Stop tape when rubber treads actuate switches. Prevent pulling tape completely off reels.

5-6. OPERATING PROCEDURES

The operating procedures and tasks listed or described in the following paragraphs are those you must perform at the tape unit or at the transition cabinet. The following paragraphs describe the procedures for daily preparation of the unit, tape loading and changing, changing the tape wiper, and changing the logical designation of the tape unit.

5-7. Preparation: Daily Inspection

The operator should inspect and clean each tape unit daily, prior to using it for the day's run. If any unsatisfactory condition exists, notify the customer engineer. If possible, use a spare tape unit (by changing UNISERVO-SELECT line connections at the patch panel as described under heading 5-11) to replace a unit that requires maintenance.

Prepare and inspect each tape unit (with a-c power on) as follows:

- (1) Clean heads and tape guides by wiping with finger. Be sure your finger is clean and dry.
- (2) Inspect tape wiper. Replace when 1 inch or less of clean surface remains.
- (3) Examine tape-unit leader for wear, scratches, rough or wrinkled edges.
- (4) Observe all photocell exciter lamps. Notify customer engineer if any exciter lamp does not light.
- (5) Observe all control-panel indicators for dark spots, which indicate defective lamps. Notify customer engineer if any indicator shows a dark spot, but this condition alone is not cause for taking unit off line.
- (6) Inspect tape clamps for worn or missing pads.
- (7) Test reel-brake release switch by releasing tape clamp. Reel brakes should release to enable reels to be turned by hand.
- (8) Inspect vacuum-loop boxes for dirt, fragments of tape, or other foreign matter.

5-8. Loading Tape

To load tape on a UNISERVO IIA tape unit, follow the instructions given in the Procedure column of table 5-4, and illustrated in figures 5-4 and 5-5. If indications described in Remarks column do not occur, notify the customer engineer.

5-9. Changing Tapes

A rewind-with-interlock instruction starts a rewind operation and lights the BACKWARD, REWIND, and CHANGE TAPE indicators on the tape-unit control panel. The BACKWARD and REWIND indicators are extinguished at the end of the rewind operation, but the CHANGE TAPE indicator remains lit. The tape unit will not operate under system control until the operator clears the interlock by turning off the unit.

Table 5-4. Tape-Loading Procedure, UNISERVO IIA Tape Unit

Step	Procedure	Remarks
1	If the ON indicator is lighted, push the OFF pushbutton.	Extinguishes ON indicator and CHANGE TAPE indicator, lights OFF indicator.
2	Unlock and lower the tape-panel door. Lock it in the open position.	
3	Examine the reel to be loaded for proper winding (oxide out), and file-protection ring if tape is a master file.	Remove retaining band.
4	Push the reel, label side out, onto the supply-reel hub. (Press near the hub.) Push until the reel latches securely in place.	See figure 5-4. If reel contains a file-protection ring, INHIBIT WRITE indicator lights.
5	Rotate the supply reel to unreel a convenient length of leader.	
6	Inspect and connect the leaders. Be sure the tape is not twisted when connected. Hook faces away from recording side.	See figure 5-5.
7	Release the tape clamp.	
8	Close tape-panel door.	
9	Push the ON pushbutton.	OFF indicator extinguishes, ON indicator lights, vacuum pulls tape taut, tape-unit numeral lights white.

To change a tape on a tape unit that has a rewind interlock in effect, follow the instructions in the Procedure column of table 5-5.

5-10. Changing Tape Wiper

To change a tape wiper, turn off the unit, open the tape-path shield, and proceed as follows:

- (1) Grasp cloth belt as shown in figure 5-7, and pull both sides in direction shown.
- (2) Release belt from drive roller, allow tension spring to retract, and remove belt from wiper assembly.
- (3) Thread clean belt on tension rollers, stretch tension spring as in step 1, and slip new belt

around drive roller. Be sure nap side of belt is out. Align belt on drive roller.

CAUTION

The drive roller turns in a counterclockwise direction. Do not try to turn it clockwise when aligning the belt.



Figure 5-4. Mounting Supply Reel



Figure 5-5. Connecting Leaders, Wire Clip Connector

Table 5-5. Tape-Changing Procedure, UNISERVO IIA Tape Unit

Step	Procedure	Remarks
1	Push the OFF push-button.	CHANGE TAPE and ON indicators extinguish, OFF indicator lights.
2	Open the tape-panel door, bring the tape connector to a convenient position, and clamp the leader.	See figure 5-2.
3	Disconnect the tape from the leader.	
4	Grasp the reel lightly by the edges with your fingertips, press the reel-release button with your thumbs until the reel slides off the hub.	See figure 5-6. If reel contains a file-protection ring, INHIBIT WRITE indicator extinguishes when reel is removed.
5	Remove the reel, mark it, and load the next reel.	Refer to table 5-4. Use retaining band to maintain proper winding tension.



Figure 5-6. Releasing Supply Reel

5-11. Exchanging Tape Units

A tape unit requires two coincident control signals to start any operation. An operation-control signal is applied to corresponding control elements in all tape units in the same group. The second signal, a

tape-unit select signal, designates the tape unit which is to respond and is applied to all control elements in that unit.

The UNISERVO IIA tape-unit-select patch panel in the transition cabinet (figure 5-8) provides the facility to select a particular tape unit for operation. Receptacles (0-5), at the top of the patch panel are connected to UNISERVO IIA tape units (0-5). Six cords (0-5), fixed at the lower end of the panel, plug into the receptacles on top. These cords are the select signal lines from the UNISERVO synchronizer in the processor. The number of each cord is the logical number used by the system to specify an individual tape unit in the group for operation.

You may designate any tape unit in the group by any logical number available at the patch panel by plugging the appropriate select signal line into the desired receptacle at the top of the panel. For example, the fourth unit in the line of tape units may be designated logical unit 2 by connecting select-signal line 2 to tape-unit receptacle 3. All signals that appear on select-signal line 2 will be applied to the fourth tape unit.

Whenever you change the logical designation of a tape unit, change the unit numeral block (figure 5-2) to correspond to the patch panel change. To remove a unit numeral block, raise the block slightly and pull it forward and out of the control panel. To insert the numeral block, insert the block in the panel opening top edge first; push the block upward until the lower edge clears the panel opening; then push the lower edge into the opening until the numeral frame is tight against the panel.



Figure 5-7. Changing Tape Wiper

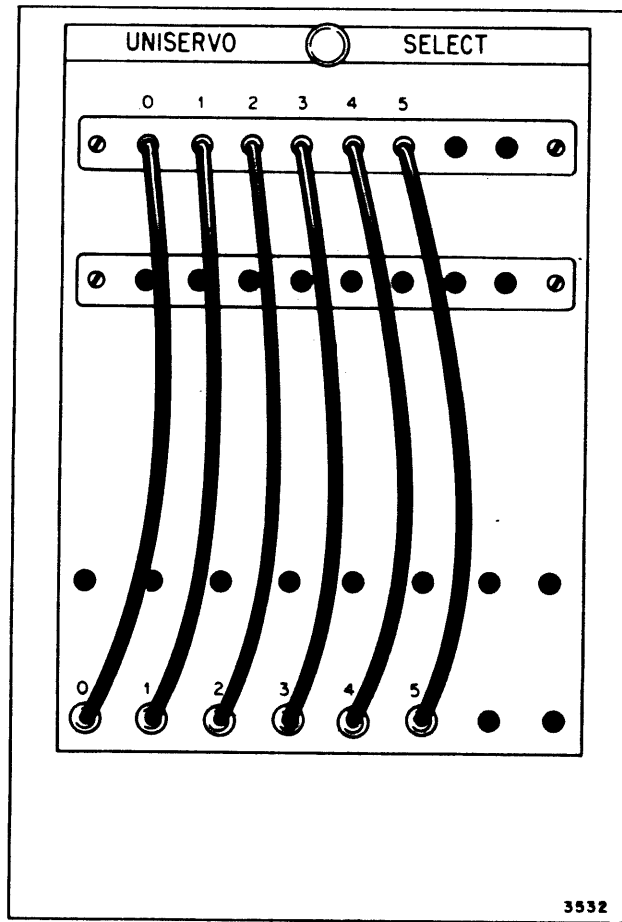

Figure 5-8. UNISERVO IIA
Tape-Unit-Select Patch Panel

Section 6

CARD READER MODEL 133

6-1. DESCRIPTION

The Card Reader Model 133 (figure 6-1) is an input unit of the UNIVAC III system. It reads 80-column

cards at a rate of 700 cards per minute under program control. The card reader consists of a card-handling mechanism, two read stations, and control circuits. The card-reader synchronizer and its

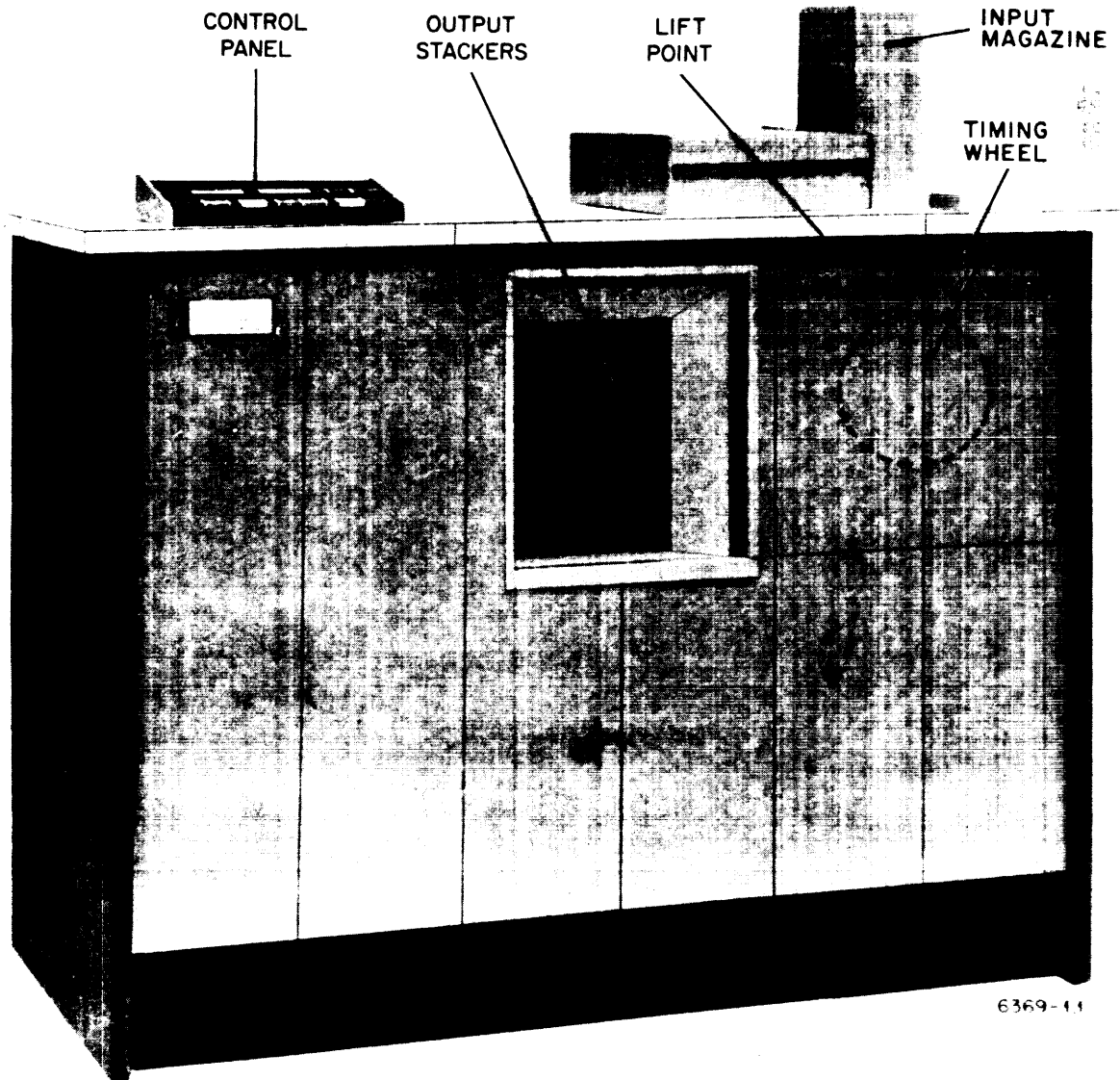

Figure 6-1. Card Reader Model 133

power supply are in the card-reader cabinet, but do not require your attention.

6-2. Card-Handling Mechanism

The card-handling mechanism consists of a 2000-card input magazine, a card-feed assembly, feed rolls, and three 1000-card output stackers. During a card cycle, the card-handling mechanism feeds a card from the input magazine and transports it through the two read stations to an output stacker in one uninterrupted operation. Card feeding and stacker selection are under program control.

Figure 6-2 is a simplified diagram of the card path. When the system calls for a card to be read, a pickerknife pushes the bottom card in the input magazine into the first set of feed rolls. The continuously moving feed rolls grip the card and carry it through the read stations to the stackers. At the stackers, the system either energizes one of two stacker selectors to deflect the card into stacker 1 or stacker 2, or allows the card to continue to the last stacker, 0. A stacker selector consists of a lever and an actuating coil. When the coil is energized, it raises one end of the lever into the card path. The lever intercepts cards and deflects them into the stacker below it. The system program usually directs properly read cards to stackers 1 and 2, and allows misread cards to fall into stacker 0.

Each stacker, when completely filled, actuates a switch that lights an indicator on the control panel and stops the reader. An empty input magazine also lights an indicator and stops the reader.

If the card reader receives no instructions from the system within a predetermined time, the drive motor stops, but the motor-control circuits remain on.

6-3. Read Stations

The two read stations each consist of a brush assembly and a metal sensing roll. The brush assembly contains a row of 80 small wire brushes, all touching the sensing roll. As a card enters a read station, it passes between the brushes and the sensing roll and lifts the brushes from the roll. As the card continues through the read station, any hole in the card allows a brush to touch the sensing roll and pass a signal. The brush assemblies may be removed for access to the feed and sensing rolls.

Signals from the two read stations are sent to the synchronizer. For each card, signals from the second station are compared with signals from the first station. If the two sets of signals correspond exactly, the system accepts the information and energizes one of two stacker selectors to deflect the card into stacker 1 or stacker 2. If the two sets of signals do not correspond exactly, the system rejects the information and allows the card to pass over stackers 1 and 2, and fall into the last stacker, stacker 0.

6-4. Controls

The control circuits (1) enable the system, through the synchronizer, to control card feeding and stacker selection, (2) stop the reader if any abnormal condition occurs, and (3) provide for limited control from the reader control panel. Table 6-1 lists and describes the controls and indicators on the reader control panel. Figure 6-3 shows the control panel.

6-5. OPERATING PROCEDURES

The procedures described in the following paragraphs are those you must perform at the card reader. System operation is described in software operation instructions in other publications.

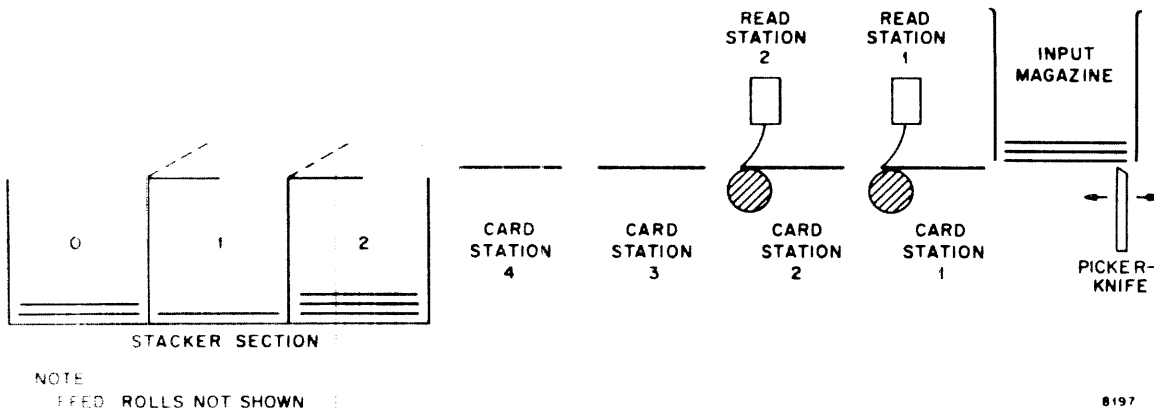

Figure 6-2 Card-Feed Path

Table 6-1. Control Panel, Card Reader Model 133

Component type is abbreviated as follows:

S—Pushbutton (switch) only,
 L—Indicator (lamp) only, and
 S/L—Combined pushbutton and indicator.

Pushbutton or Indicator			Function or Indication
Marking	Color	Type	
SYNCHRONIZER			
OVERHEAT	Red	L	OVERHEAT indicator lights to show that synchronizer temperature has exceeded 120°F. The d-c power is off.
AIR FLOW			AIR FLOW indicator lights to show that air flow failure has occurred. The d-c power is off.
CARD STATUS			
FEED JAM	Yellow	L	FEED JAM indicator lights when a card-feed jam or a registration error occurs at a read station. Drive motor is off.
STACK JAM			STACK JAM indicator lights to indicate a card jam at stacker. Drive motor is off.
STACK FULL	Yellow	L	Indicator lights to show that a stacker is full. Next card feed is inhibited.
MISFEED	Yellow	L	Indicator lights when feed hopper is empty or a misfeed occurs. Next card feed is inhibited and drive motor is off.
COVERS			
READ ERROR	Red	S/L	READ ERROR indicator lights when read error occurs.
INTERLOCK	Yellow		INTERLOCK indicator lights when a door is open. Pressing pushbutton clears READ ERROR circuitry.
POWER			
DC ON	Green	S/L	Indicator lights when d-c power is on. Pressing pushbutton turns on or turns off d-c power. (Turning off d-c power, either manually or as the result of a fault, also turns off the drive motor.)
CAUTION			
Do not turn off d-c power unless unit is off line.			

Table 6-1. Control Panel, Card Reader Model 133 (cont)

Pushbutton or Indicator			Function or Indication
Marking	Color	Type	
MOTOR ON	Green	S/L	Indicator lights when drive motor circuits are turned on. Pressing pushbutton turns on or turns off drive motor. (Has no effect unless d-c power is on.)
FEED			
ONE CARD	White	S	Pressing pushbutton causes reader to feed one card. Pushbutton can be used to perform initial load operation from reader when memory is clear.
OPERATIONS			
OFF-LINE	Blue	S/L	Indicator lights when reader is off line (not under system control). Pressing pushbutton logically disconnects reader from system control.
<div style="border: 1px solid black; padding: 5px; margin: 10px auto; width: 80%;"> <p style="text-align: center; margin: 0;">CAUTION</p> <p style="text-align: center; margin: 0;">Do not press OFF-LINE pushbutton while cards are being fed.</p> </div>			
ABNORMAL CLEAR	Red	S/L	Indicator lights when fault occurs. Pressing pushbutton clears error circuits in reader synchronizer.

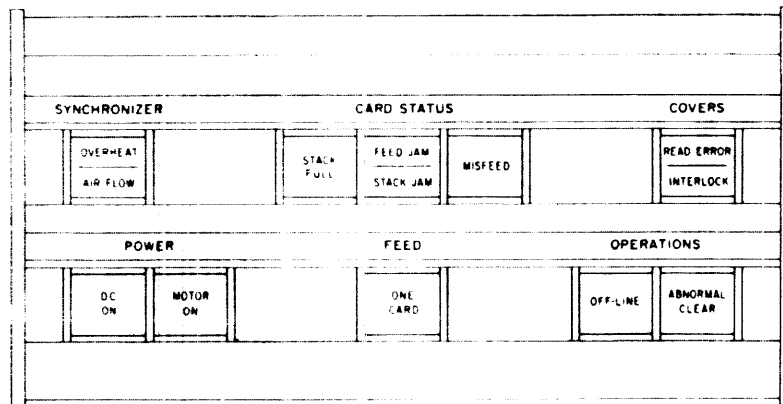

Figure 6-3. Card-Reader Control Panel

Table 6-2. Card-Reader Inspection and Cleaning

Step	Procedure	Remarks	Step	Procedure	Remarks
1	Remove brush assemblies and inspect for damage and wear.	See figures 6-4 and 6-5.	4	Inspect feed-roll assemblies for loss of tension.	Notify customer engineer of any defects.
2	Clean card path.	Refer to table 6-4.	5	Inspect card path for loose parts or foreign matter.	
3	Inspect for defective lamps in control-panel indicators and in stackers.	See figure 6-6. Defective lamps cause dark spots in indicators. Notify customer engineer if any lamp is defective.	6	Observe condition and placement of tinsel strand at stacker 1.	
			7	Test action of throat-knife latch detent.	See figure 6-7. Weak detent may cause feed jams.

6-6. Preparation: Daily Inspection and Cleaning

To prepare the card reader for operation, perform the steps listed in table 6-2. Tables 6-3 and 6-4 give detailed instructions for steps 1 and 2 of table 6-2.

6-7. During Operation

During system operation, your principal tasks will

be to load cards into the input magazine and remove cards from the output stackers. Loading procedures are described in section 2. To remove cards from the output stackers, wait until a full stacker stops the reader. Don't remove cards from a stacker into which cards are still falling. To do so may cause a stacker jam. Cards may be added to the input magazine at any time.

Table 6-3. Removing and Replacing Brush Assemblies

WARNING

Steps b2 and b3 involve exposed moving parts. Do not wear loose clothing, dangling neckties, scarves, or loose or pendent jewelry near moving machinery. By observing this precaution, these steps may be carried out safely.

Step	Procedure	Remarks	Step	Procedure	Remarks
<i>a. Removing Brush Assemblies</i>			<i>b. Replacing Brush Assemblies (cont)</i>		
1	Press OFF-LINE push-button.	OFF-LINE indicator should light.	2	With MOTOR ON indicator lit, press ONE CARD pushbutton to start motor.	See WARNING. Motor runs for several seconds, then stops.
2	Open card-path cover. Push brush lock levers to left to unlock brush assemblies. Lift out assemblies. Place brush assemblies in racks provided.	See figure 6-4.	3	Release locks and lower brush assemblies. Lock in position.	See figure 6-4 for proper method. Sensing rolls must be turning when brushes are lowered into contact. Repeat step 2 if necessary.
<i>b. Replacing Brush Assemblies</i>			4	Close covers and return reader to normal operation.	
1	Place brush assemblies in read station channels, lock-levers to right.	Do not push down or lock.			

6-8. In Case of Trouble

Occasionally, minor malfunctions such as card jams or misread cards will stop the reader. Either trouble can occur if worn or damaged cards are fed into the reader. The following paragraphs give the procedures for correcting such troubles.

6-9. MISREAD AND REJECTED CARDS. Misread cards usually fall in stacker 0. If the deck is sequence-sensitive (sequence of the cards in the deck is significant), the program stops the reader. If the reader stops, and there are cards in stacker 0 and in the input magazine, you must refeed the misread cards immediately, in their original sequence. Refer to table 6-5 for this procedure.

Table 6-4. Cleaning Card Path

Step	Procedure	Remarks
1	Remove brush assemblies from read stations and place in rack.	Refer to table 6-3a. Examine brushes for uneven wear, bends, or kinks (figure 6-5).
2	Brush lint and dust from card path with soft brush.	
3	Wipe sensing rolls, feed rolls, and stackers, with a soft lint-free cloth.	
4	Replace brush assemblies.	Refer to table 6-3b.

When the deck is not sequence-sensitive, misread cards may fall in stacker 0 but may not stop the reader. Such cards may be fed by placing them in the input magazine at any time, without regard to sequence.

An excessive number of misread cards may indicate that the reader needs adjustment. When the reader consistently misreads more than one card for every 5000 cards fed, notify your supervisor.

6-10. CARD JAMS. Card jams may occur at the feed throat, at either read station, or at the stackers. If a jam occurs, follow the instructions in table 6-6. If any card is damaged, notify your supervisor as soon as the jam is cleared.

Table 6-5. Refeeding Rejected Sequence-Sensitive Cards

Step	Procedure	Remarks
1	Remove all cards from the input magazine.	
2	Place the rejected cards in the input magazine.	
3	Reload cards unloaded in step 1, press ABNORMAL CLEAR pushbutton to start reader.	Reader should start and feed cards. Run should continue.



Figure 6-4. Removing Brush Assemblies



Figure 6-5. Inspecting Brushes

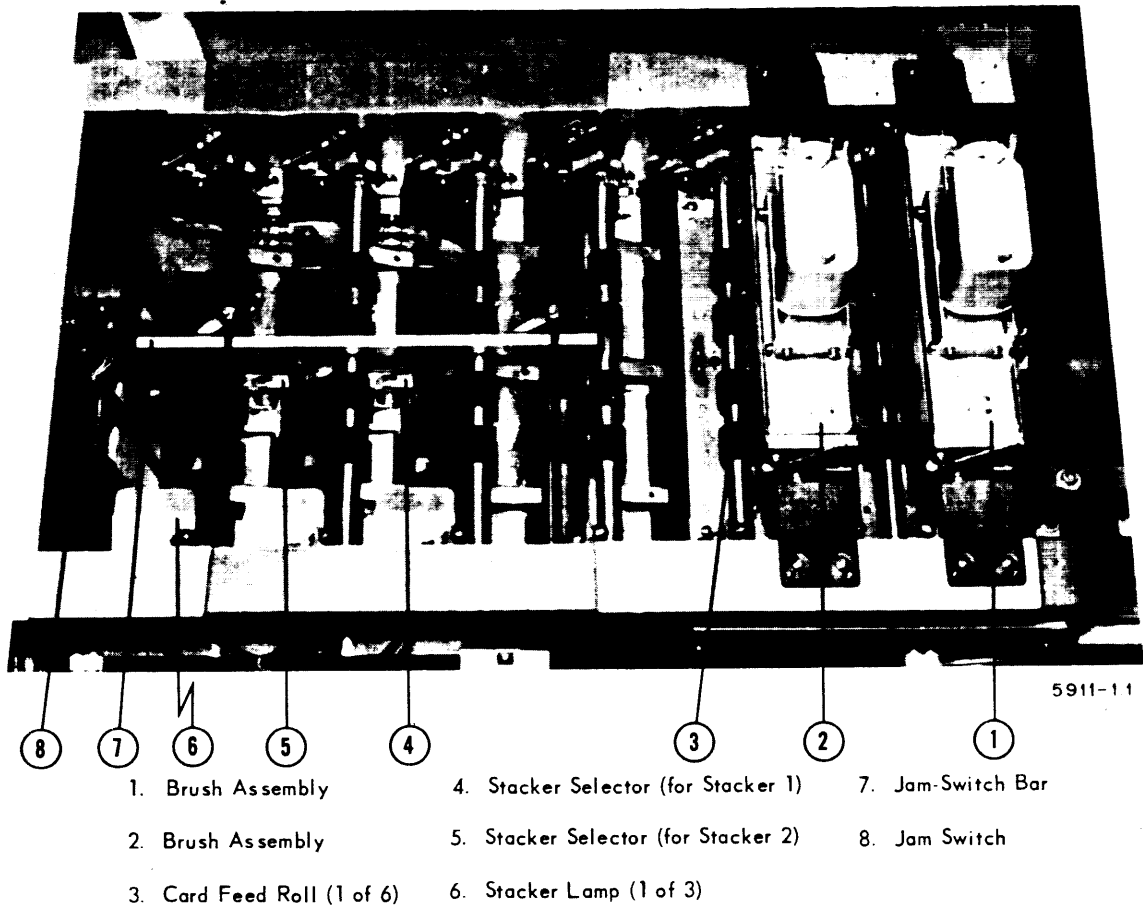

Figure 6-6. Stackers, Top View

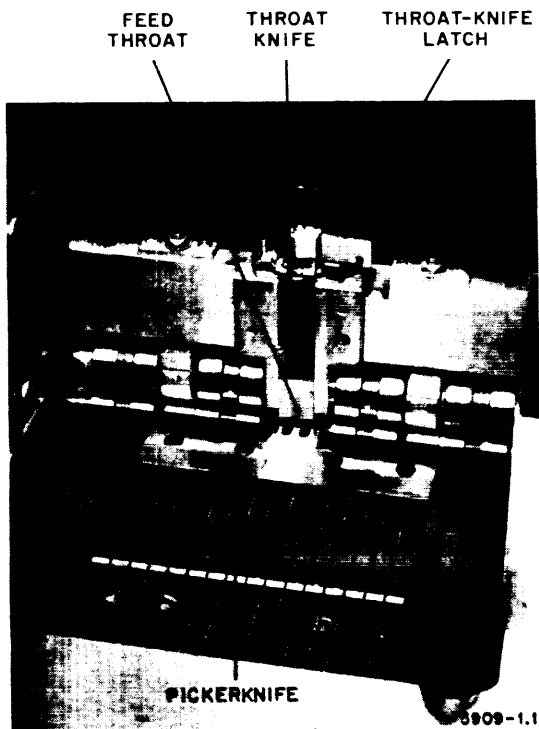

Figure 6-7. Card-Reader Input Magazine

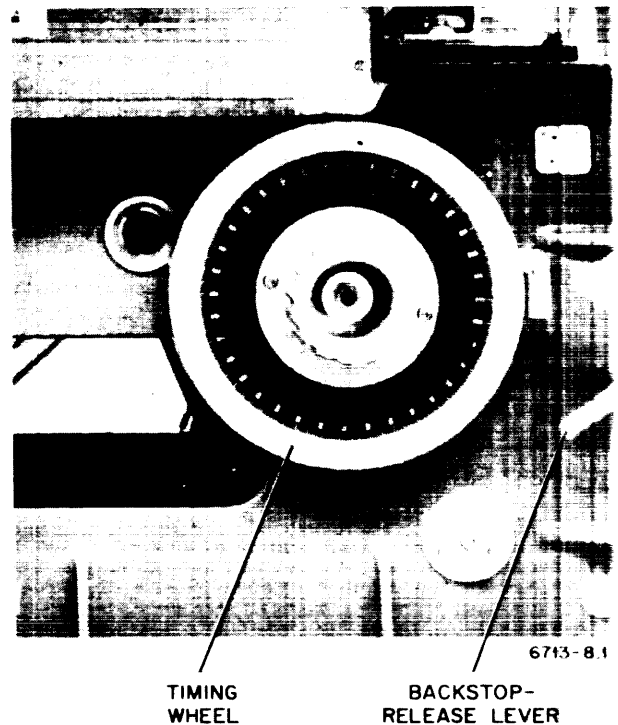

Figure 6-8. Timing Wheel

Table 6-6. Clearing Card Jams

Step	Procedure	Remarks	Step	Procedure	Remarks
1	Press OFF-LINE pushbutton to place reader in off-line condition; press DC ON pushbutton to turn off d-c power in reader.	OFF-LINE indicator should light; DC ON and MOTOR ON indicators should extinguish. Lighted CARD STATUS indicator should extinguish.		turn timing wheel clockwise to free any remaining pieces of card.	
2	Open feed-track cover.		8	Lower backstop-release lever. Turn timing wheel counterclockwise until backstop engages. Close timing-wheel door.	See figure 6-8.
3	Remove brush assemblies and place in racks provided. Inspect brushes for damage.	Refer to table 6-3. See figures 6-4 and 6-5.	9	Replace brush assemblies in read stations. Close feed-track cover.	Refer to table 6-3.
4	Remove cards from input magazine and release throat knife.	See figure 6-7. Omit this step if no jam at throat.	10	Close throat latch and load input magazine.	MISFEED indicator should extinguish if lighted. Omit if step 4 was omitted.
5	Unload stackers.		11	Press DC ON pushbutton to turn on d-c power; push MOTOR ON pushbutton to start motor; press ABNORMAL CLEAR pushbutton to clear error circuits.	DC ON and MOTOR ON indicators should light; ABNORMAL CLEAR indicator should extinguish.
6	Open timing-wheel door. Turn timing wheel counterclockwise to free damaged cards. Remove cards.	See figure 6-8. If jam occurred at stackers, be sure jam-switch bar (figure 6-6) returns to normal position.	12	Press OFF-LINE pushbutton.	OFF-LINE indicator should extinguish.
7	Raise and hold backstop-release lever and				

Section 7 CARD READER MODEL 182

7-1. DESCRIPTION

The Card Reader Model 182 (figure 7-1) is an input unit of the UNIVAC III system. It reads 90-column

cards at a rate of 700 cards per minute under program control. The card reader consists of a card-handling mechanism, two read stations, and control circuits. The card-reader synchronizer and its

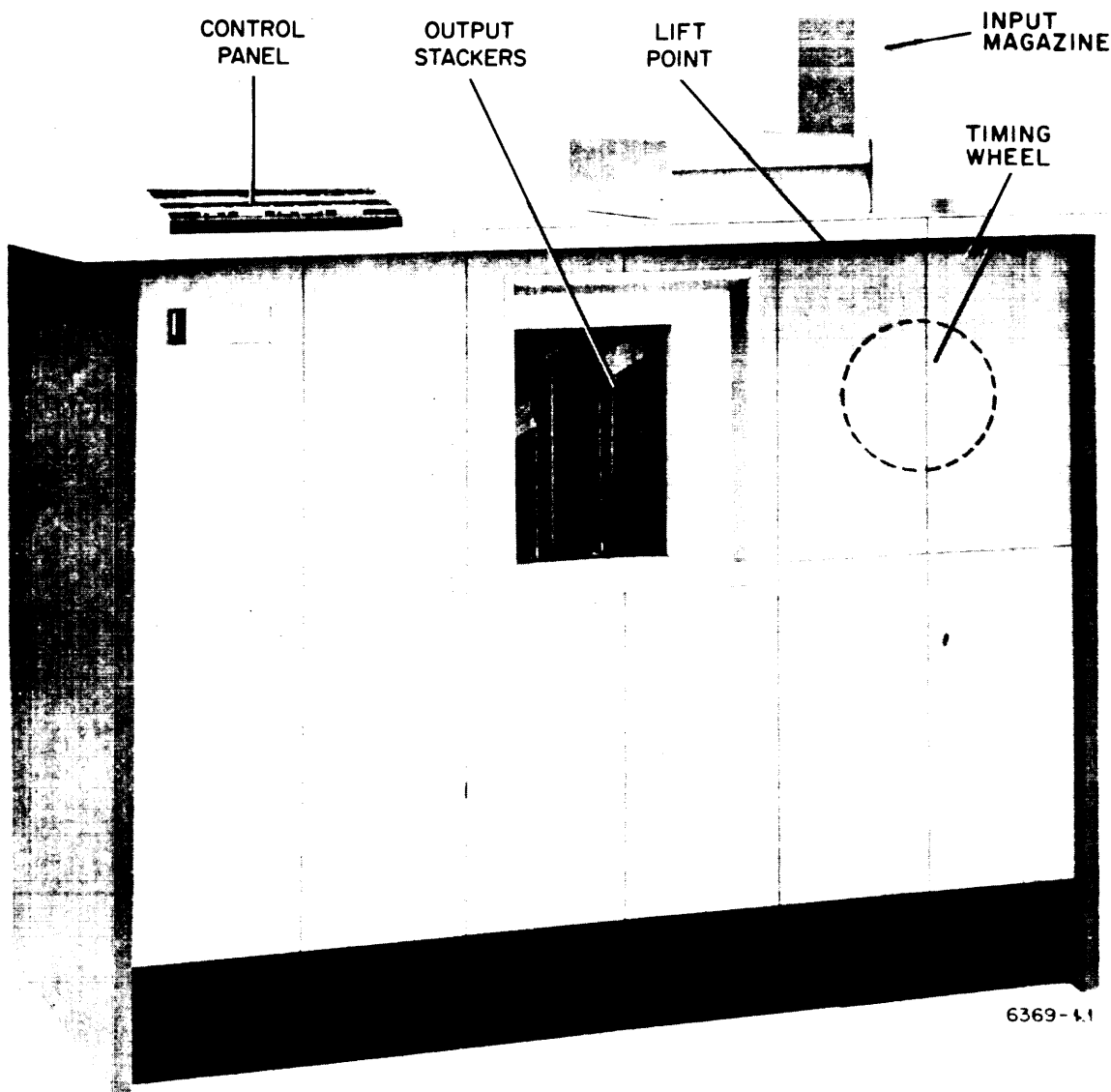

6369-1.1

Figure 7-1. Card Reader Model 182

power supply are in the card-reader cabinet, but do not require your attention.

7-2. Card-Handling Mechanism

The card-handling mechanism consists of a 2000-card input magazine, a card-feed assembly, feed rolls, and three 1000-card output stackers. During a card cycle, the card-handling mechanism feeds a card from the input magazine and transports it through the two read stations to an output stacker in one uninterrupted operation. Card feeding and stacker selection are under program control.

Figure 7-2 is a simplified diagram of the card path. When the system calls for a card to be read, a pickerknife pushes the bottom card in the input magazine into the first set of feed rolls. The continuously moving feed rolls grip the card and carry it through the read stations to the stackers. At the stackers, the system either energizes one of two stacker selectors to deflect the card into stacker 1 or stacker 2, or allows the card to continue to the last stacker, stacker 0. A stacker selector consists of a lever and an actuating coil. When the coil is energized, it raises one end of the lever into the card path. The lever intercepts cards and deflects them into the stacker below it. The system program usually directs properly read cards to stackers 1 and 2, and allows misread cards to fall into stacker 0.

Each stacker, when completely filled, actuates a switch that lights an indicator on the control panel and causes the reader to stop. An empty input magazine also lights an indicator and stops the reader.

If the card reader receives no instruction from the system within a predetermined time, the drive motor stops, but the motor-control circuits remain on.

7-3. Read Stations

The two read stations each consist of a brush assembly and a metal sensing roll. The brush assembly contains a row of 45 small wire brushes, all touching the sensing roll. As a card enters a read station, it passes between the brushes and the sensing roll and lifts the brushes from the roll. As the card continues through the read station, any hole in the card allows a brush to touch the sensing roll and pass a signal. The brush assemblies may be removed for access to the feed and sensing rolls.

Signals from the two read stations are sent to the synchronizer. For each card, signals from the second station are compared with signals from the first station. If the two sets of signals correspond exactly, the system accepts the information and energizes one of two stacker selectors to deflect the card into stacker 1 or stacker 2. If the two sets of signals do not correspond exactly, the system rejects the information and allows the card to pass over stackers 1 and 2, and fall into the last stacker, stacker 0.

7-4. Controls

The control circuits (1) enable the system, through the synchronizer, to control card feeding and stacker selection, (2) stop the reader if any abnormal condition occurs, and (3) provide for limited control from the reader control panel. Table 7-1 lists and describes the controls and indicators on the reader control panel. Figure 7-3 shows the control panel.

7-5. OPERATING PROCEDURES

The procedures described in the following paragraphs are those you must perform at the card reader. System operation is described in software operation instructions in other publications.

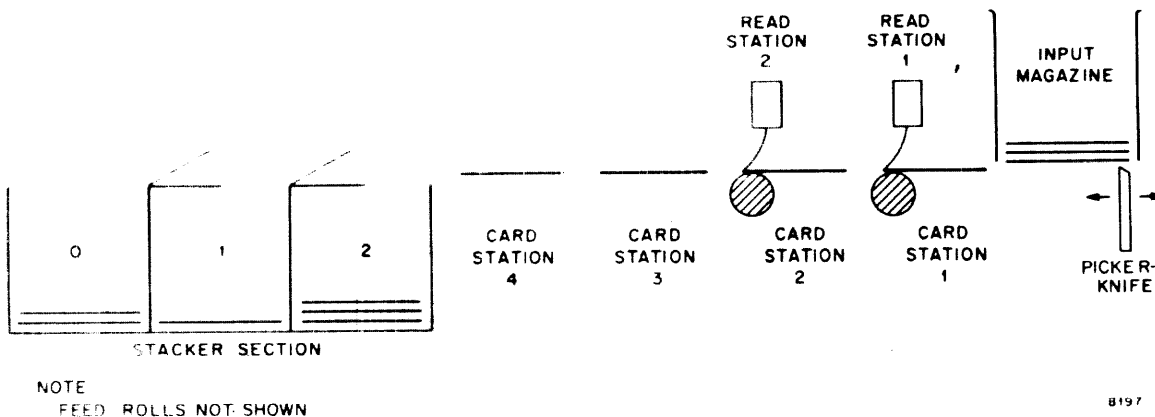

Figure 7-2. Card-Feed Path

Table 7-1. Control Panel, Card Reader Model 182

Component type is abbreviated as follows:

S—Pushbutton (switch) only,
 L—Indicator (lamp) only, and
 S/L—Combined pushbutton and indicator.

Pushbutton or Indicator			Function or Indication
Marking	Color	Type	
SYNCHRONIZER			
OVERHEAT	Red	L	OVERHEAT indicator lights to show that synchronizer temperature has exceeded 120°F. The d-c power is off.
AIR FLOW			AIR FLOW indicator lights to show that air flow failure has occurred. The d-c power is off.
CARD STATUS			
FEED JAM	Yellow	L	FEED JAM indicator lights when a card-feed jam or a registration error occurs at a read station. Drive motor is off.
STACK JAM			STACK JAM indicator lights to indicate a card jam at stacker. Drive motor is off.
STACK FULL	Yellow	L	Indicator lights to show that a stacker is full. Next card feed is inhibited.
MISFEED	Yellow	L	Indicator lights when feed hopper is empty or a misfeed occurs. Next card feed is inhibited and drive motor is off.
COVERS			
READ ERROR	Red	S/L	READ ERROR indicator lights when read error occurs.
INTERLOCK	Yellow		INTERLOCK indicator lights when a door is open. Pressing pushbutton clears READ ERROR circuitry.
POWER			
DC ON	Green	S/L	Indicator lights when d-c power is on. Pressing pushbutton turns on or turns off d-c power. (Turning off d-c power, either manually or as the result of a fault, also turns off the drive motor.)
CAUTION			
Do not turn off d-c power unless unit is off line.			

Table 7-1. Control Panel, Card Reader Model 182 (cont)

Pushbutton or Indicator			Function or Indication
Marking	Color	Type	
MOTOR ON	Green	S/L	Indicator lights when drive motor circuits are turned on. Pressing pushbutton turns on or turns off drive motor. (Has no effect unless d-c power is on.)
FEED			
ONE CARD	White	S	Pressing pushbutton causes reader to feed one card. Switch can be used to perform initial load operation from reader when memory is clear.
OPERATIONS			
OFF-LINE	Blue	S/L	Indicator lights when reader is off line (not under system control). Pressing pushbutton logically disconnects reader from system control.
<div style="border: 1px solid black; padding: 5px; margin: 10px auto; width: 80%;"> <p style="text-align: center;">CAUTION</p> <p style="text-align: center;">Do not press OFF-LINE pushbutton while cards are being fed.</p> </div>			
ABNORMAL CLEAR	Red	S/L	Indicator lights when fault occurs. Pressing pushbutton clears error circuits in reader synchronizer.

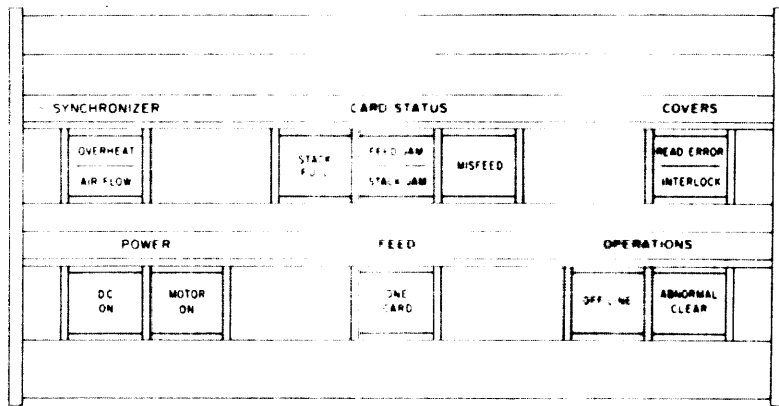

Figure 7-3. Card-Reader Control Panel

Table 7-2. Card-Reader Inspection and Cleaning

Step	Procedure	Remarks	Step	Procedure	Remarks
1	Remove brush assemblies and inspect for damage and wear.	See figures 7-4 and 7-5.	4	Inspect feed-roll assemblies for loss of tension.	Notify customer engineer of any defects.
2	Clean card path.	Refer to table 7-4.	5	Inspect card path for loose parts for foreign matter.	
3	Inspect for defective lamps in control-panel indicators and in stackers.	See figure 7-6. Defective lamps cause dark spots in indicators. Notify customer engineer if any lamp is defective.	6	Observe condition and placement of tinsel strand at stacker 1.	If worn, missing, or out of place, notify customer engineer.
			7	Test action of throat-knife latch detent.	See figure 7-7. Weak detent may cause feed jams.

7-6. Preparation: Daily Inspection and Cleaning

To prepare the card reader for operation, perform the steps listed in table 7-2. Tables 7-3 and 7-4 give detailed instructions for steps 1 and 2 of table 7-2.

7-7. During Operation

During system operation, your principal tasks will

be to load cards into the input magazine and remove cards from the output stackers. Loading procedures are described in section 2. To remove cards from the output stackers, wait until a full stacker stops the reader. Don't remove cards from a stacker into which cards are still falling. To do so may cause a stacker jam. Cards may be added to the input magazine at any time.

Table 7-3. Removing and Replacing Brush Assemblies

WARNING

Steps b2 and b3 involve exposed moving parts. Do not wear loose clothing, dangling neckties, scarves, or loose or pendent jewelry near moving machinery. By observing this precaution, these steps may be carried out safely.

Step	Procedure	Remarks	Step	Procedure	Remarks
<i>a. Removing Brush Assemblies</i>			<i>b. Replacing Brush Assemblies (cont)</i>		
1	Press OFF-LINE pushbutton.	OFF-LINE indicator should light.	2	With MOTOR ON indicator lit, press ONE CARD pushbutton to start motor.	See WARNING. Motor runs for several seconds, then stops.
2	Open card-path cover. Push brush lock levers to left to unlock brush assemblies. Lift out assemblies. Place brush assemblies in racks provided.	See figure 7-4.	3	Release locks and lower brush assemblies. Lock in position.	See figure 7-4 for proper method. Sensing rolls must be turning when brushes are lowered into contact. Repeat step 2 if necessary.
<i>b. Replacing Brush Assemblies</i>			4	Close covers and return reader to normal operation.	
1	Place brush assemblies in read station channels, lock-levers to right.	Do not push down or lock.			

7-8. In Case of Trouble

Occasionally, minor malfunctions such as card jams or misread cards will stop the reader. Either trouble can occur if worn or damaged cards are fed into the reader. The following paragraphs give the procedures for correcting such troubles.

7-9. MISREAD AND REJECTED CARDS. Misread cards usually fall in stacker 0. If the deck is sequence-sensitive (sequence of the cards in the deck is significant), the program stops the reader. If the reader stops, and there are cards in stacker 0 and in the input magazine, you must refeed the misread cards immediately, in their original sequence. Refer to table 7-5 for this procedure.

Table 7-4. Cleaning Card Path

Step	Procedure	Remarks
1	Remove brush assemblies from read stations and place in rack.	Refer to table 7-3a. Examine brushes for uneven wear, bends, or kinks (figure 7-5).
2	Brush lint and dust from card path with soft brush.	
3	Wipe sensing rolls, feed rolls, and stackers with a soft lint-free cloth.	
4	Replace brush assemblies.	Refer to table 7-3b.

When the deck is not sequence-sensitive, misread cards may fall in stacker 0 but may not stop the reader. Such cards may be fed by placing them in the input magazine at any time, without regard to sequence.

An excessive number of misread cards may indicate that the reader needs adjustment. When the reader consistently misreads more than one card for every 5000 cards fed, notify your supervisor.

7-10. CARD JAMS. Card jams may occur at the feed throat, at either read station, or at the stackers. If a jam occurs, follow the instructions in table 7-6. If any card is damaged, notify your supervisor as soon as the jam is cleared.

Table 7-5. Refeeding Rejected Sequence-Sensitive Cards

Step	Procedure	Remarks
1	Remove all cards from the input magazine.	
2	Place the rejected cards in the input magazine.	
3	Reload cards unloaded in step 1, press ABNORMAL CLEAR pushbutton to start reader.	Reader should start and feed cards. Run should continue.



Figure 7-4. Removing Brush Assemblies



Figure 7-5. Inspecting Brushes

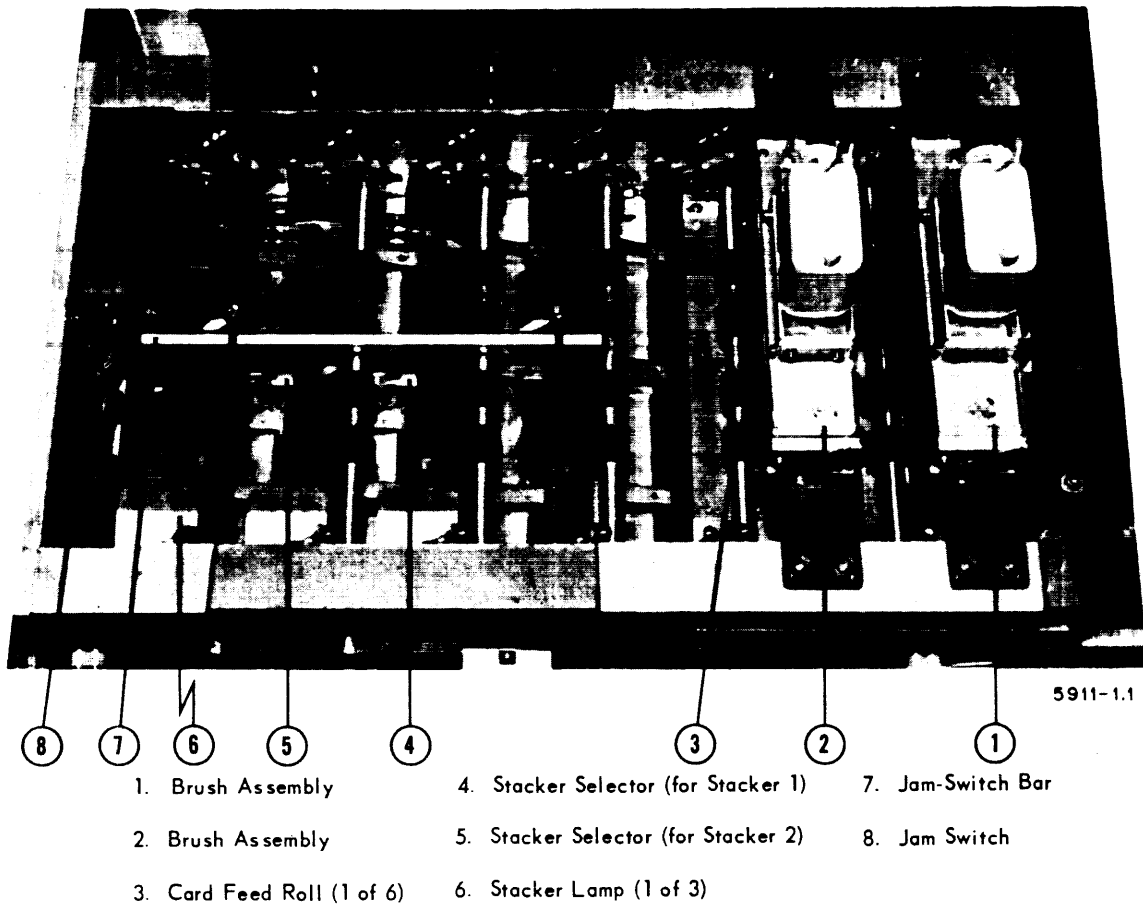

Figure 7-6. Stackers, Top View

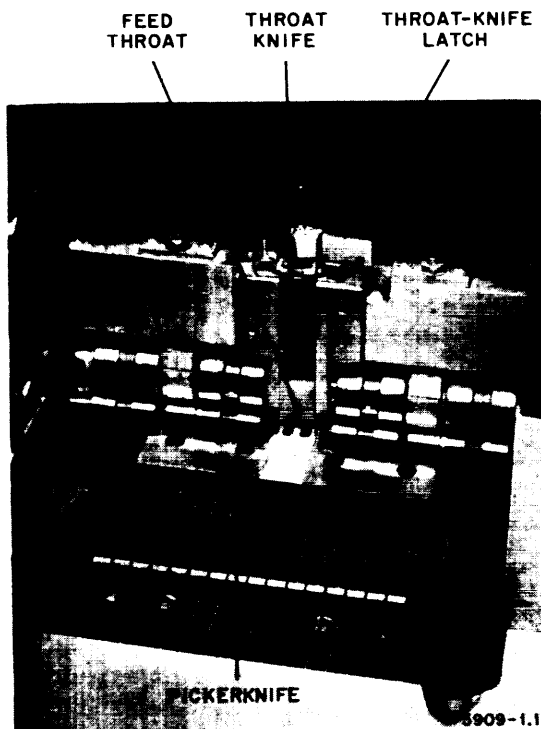

Figure 7-7. Card-Reader Input Magazine

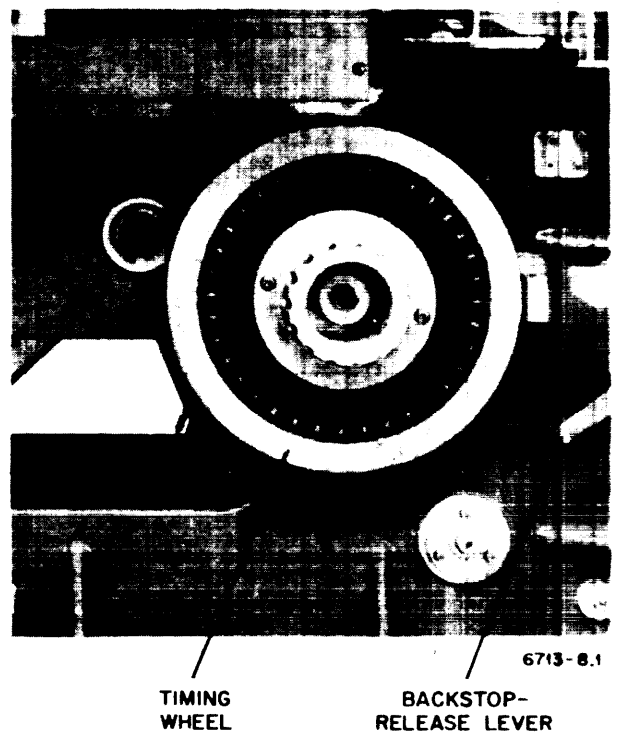

Figure 7-8. Timing Wheel

Table 7-6. Clearing Card Jams

Step	Procedure	Remarks	Step	Procedure	Remarks
1	Press OFF-LINE push-button to place reader in off-line condition; press DC ON push-button to turn off d-c power in reader.	OFF-LINE indicator should light; DC ON and MOTOR ON indicators should extinguish. Lighted CARD STATUS indicator should extinguish.		turn timing wheel clockwise to free any remaining pieces of card.	
	Open feed-track cover.		8	Lower backstop-release lever. Turn timing wheel counterclockwise until backstop engages. Close timing-wheel door.	See figure 7-8.
2	Remove brush assemblies and place in racks provided. Inspect brushes for damage.	Refer to table 7-3. See figures 7-4 and 7-5.	9	Replace brush assemblies in read stations. Close feed-track cover.	Refer to table 7-3.
3	Remove cards from input magazine and release throat knife.	See figure 7-7. Omit this step if no jam at throat.	10	Close throat latch and load input magazine.	MISFEED indicator should extinguish if lighted. Omit if step 4 was omitted.
4	Unload stackers.		11	Press DC ON push-button to turn on d-c power; press MOTOR ON pushbutton to start motor; press ABNORMAL CLEAR push-button to clear error circuits.	DC ON and MOTOR ON indicators should light; ABNORMAL CLEAR indicator should extinguish.
5	Open timing-wheel door. Turn timing wheel counterclockwise to free damaged cards. Remove cards.	See figure 7-8. If jam occurred at stackers, be sure jam-switch bar (figure 7-6) returns to normal position.	12	Press OFF-LINE pushbutton.	OFF-LINE indicator should extinguish.
6	Raise and hold backstop-release lever and				

Section 8

CARD PUNCH MODEL 127

8-1. DESCRIPTION

The UNIVAC Card Punch Model 127 (figure 8-1) is an output unit of the UNIVAC III system. It punches 80-column cards at a rate of 300 cards per minute, under program control, and reads each card to enable the system to test whether the information punched

in the card corresponds exactly to what should have been punched. The card-punch unit consists of a card-handling mechanism, a punch mechanism, a brush-type read station, and control circuits. The card-punch synchronizer and its power supply are in the card-punch unit cabinet, but do not require your attention.

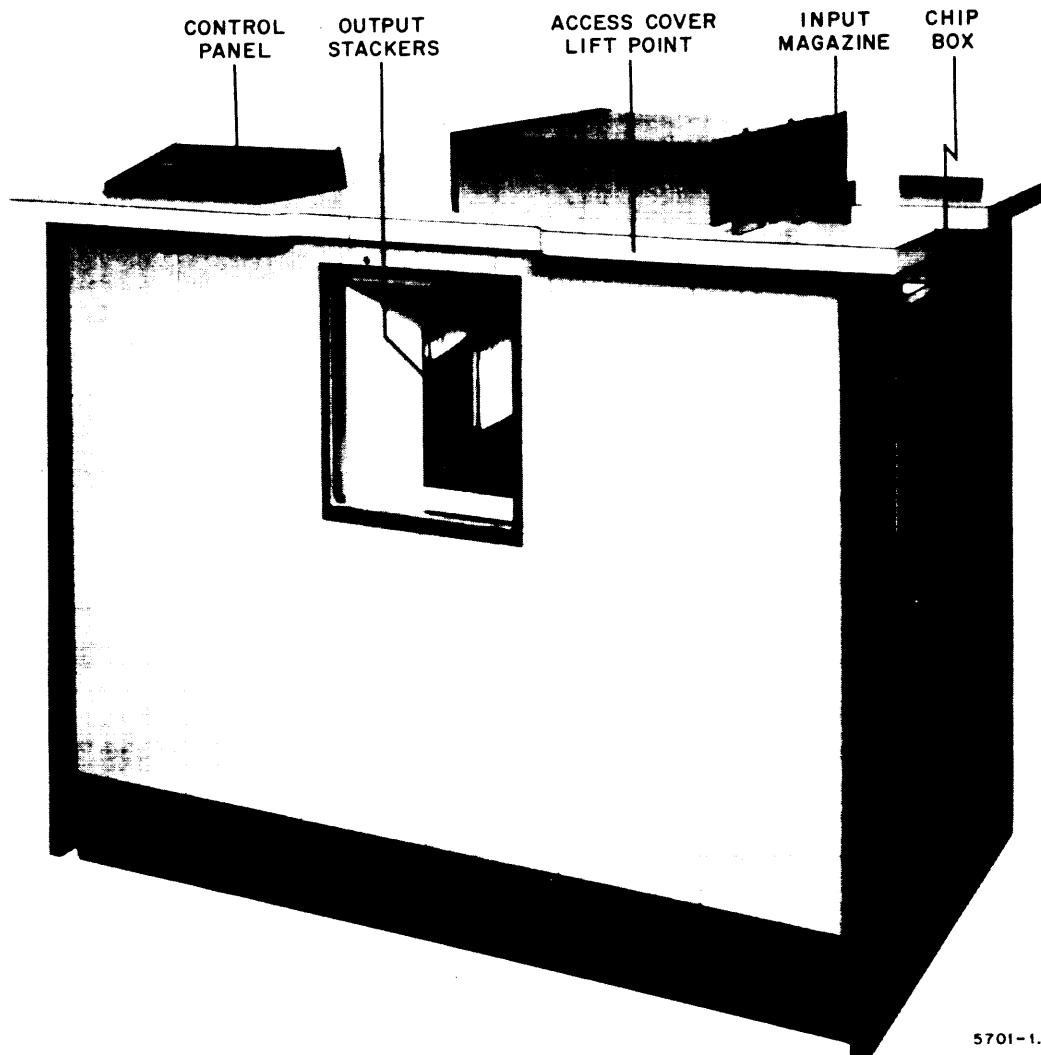

5701-1.1

Figure 8-1. Card Punch Model 127

8-2. Card-Handling Mechanism

The card-handling mechanism consists of a 1000-card input magazine, a card-feed assembly, two wait stations with feed rolls that operate intermittently, a stepping mechanism to feed each card through the punch station one row at a time, two 1000-card output stackers; and four sets of rolls that carry the card away from the punch station, through the read station, and into the output stackers.

The card-handling mechanism feeds cards from the input magazine, carries them to the punch station in a series of steps, and feeds them through the punch station one row at a time. After the card has been punched, the card-handling mechanism carries the cards from the punch station, through the read station, and into the output stackers in a continuous movement. Figure 8-2 shows the card-feed path.

8-3 Punch Station

The punch station and punch assembly are contained in the punch block, which is hinged for access to the card path and punch station. The punch assembly consists of an actuating mechanism, 80 rectangular

punches, and a die block. Cards are punched as they pass between the punches and the die block, through a slot that can pass only one card at a time. The punch block also contains a part of the card-handling mechanism.

8-4. Read Station

The read station consists of a brush holder that contains a row of 80 small wire brushes, all touching a metal sensing roll. As a card passes through a read station, it passes between the brushes and the sensing roll and lifts the brushes from the roll. As the card continues through the read station, any hole in the card allows a brush to touch the sensing roll and pass a signal.

8-5. Control Circuits

The control circuits (1) enable the system, through the synchronizer, to control card feeding, punching, and output-stacker selection, and (2) provide for limited control from the punch-unit control panel. Table 8-1 lists and describes the controls and indicators on the card-punch control panel. Figure 8-3 shows the control panel.

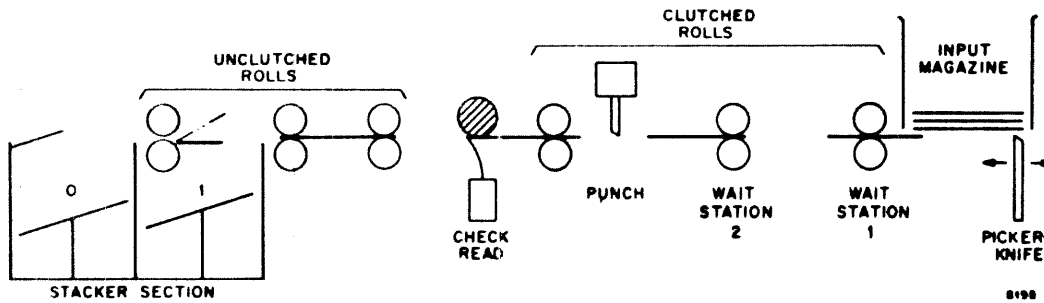

Figure 8-2. Card-Feed Path

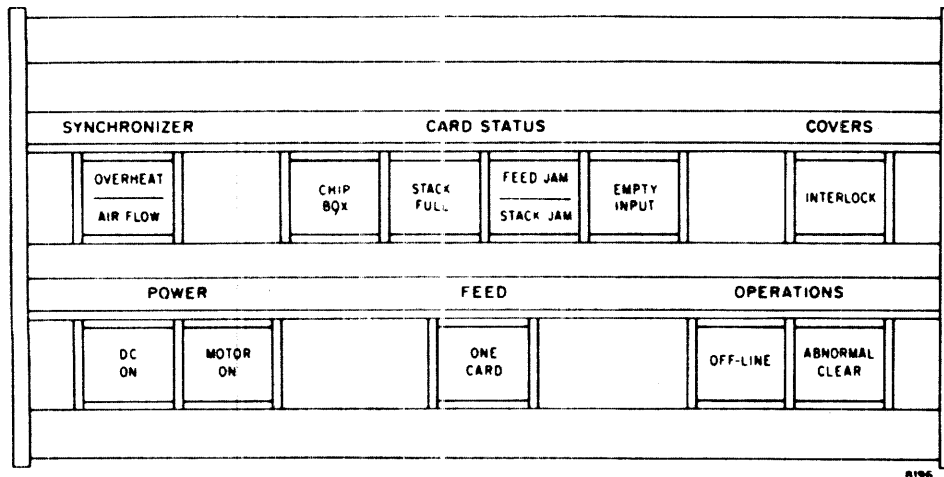

Figure 8-3. Card-Punch Control Panel

Table 8-1. Control Panel, Card Punch Model 127

Component type is abbreviated as follows:

S—Pushbutton (switch) only,
 L—Indicator (lamp) only, and
 S/L—Combined pushbutton and indicator.

Pushbutton or Indicator			Function or Indication
Marking	Color	Type	
SYNCHRONIZER			
OVERHEAT	Red	L	OVERHEAT indicator lights when synchronizer temperature has exceeded 135°F. The d-c power is off.
AIR FLOW			AIR FLOW indicator lights when air flow in synchronizer or power supply has failed or is insufficient. The d-c power is off.
CARD STATUS			
CHIP BOX	Yellow	L	Indicator lights when chip box is full or not in place.
STACK FULL	Yellow	L	STACK FULL indicator lights when a stacker is full.
FEED JAM	Red	L	FEED JAM indicator lights when card jam occurs between input magazine and stacker. Drive motor is off.
STACK JAM			STACK JAM indicator lights when card jam occurs at either stacker. Drive motor is off.
EMPTY INPUT	Yellow	L	Indicator lights when input magazine is empty.
COVERS			
INTERLOCK	Yellow	L	Indicator lights when a cabinet door is open. Drive motor is off.

Table 8-1. Control Panel, Card Punch Model 127 (cont)

Pushbutton or Indicator			Function or Indication	
Marking	Color	Type		
POWER				
DC ON	Green	S/L	Indicator lights when d-c power is on. Pressing pushbutton turns on or turns off d-c power.	
<table border="1" style="width: 100%;"> <tr> <td style="text-align: center;"> CAUTION Do not turn off d-c power unless unit is off line. </td> </tr> </table>				CAUTION Do not turn off d-c power unless unit is off line.
CAUTION Do not turn off d-c power unless unit is off line.				
MOTOR ON	Green	S/L	Indicator lights when motor-control circuits are under system control. Pressing pushbutton once places motor-control circuits under system control. Pressing pushbutton a second time disconnects motor-control circuits from system control and extinguishes indicator.	
FEED				
ONE CARD	White	S	Pressing pushbutton causes punch to feed one card. No punching occurs.	
OPERATIONS				
OFF-LINE	Blue	S/L	Indicator lights when punch is off line. Pressing pushbutton logically disconnects punch from system control. Pressing pushbutton a second time returns punch to system control.	
<table border="1" style="width: 100%;"> <tr> <td style="text-align: center;"> CAUTION Do not press OFF-LINE pushbutton while cards are being fed. </td> </tr> </table>				CAUTION Do not press OFF-LINE pushbutton while cards are being fed.
CAUTION Do not press OFF-LINE pushbutton while cards are being fed.				
ABNORMAL CLEAR	Red	S/L	Indicator lights when abnormal condition occurs. Pressing pushbutton clears error circuits in punch synchronizer.	

by allowing it to continue to output stacker 0. Valid cards fall into stacker 1. At any time during a normal punching cycle, there are three cards in the feed track: one at each wait station, and one in the punch station. Between punching cycles, there are cards at wait stations 1 and 2. Beginning with an empty feed track, the first four card cycles are as follows:

- (1) The card-feed mechanism feeds a card from the input magazine to wait station 1. The card stops until the next card-feed cycle.
- (2) On the next cycle, the card-handling mechanism moves the card at wait station 1 to wait station 2 and feeds another card to wait station 1.
- (3) During the following cycle, the first two steps are repeated, and the card at wait station 2 is stepped through the punch station, one row at a time, to a third wait station.
- (4) During the fourth cycle, the first three steps are repeated, and the card punched during the third cycle is transported by the clutched ejection rolls through the read station and into the stacker rolls. The stacker rolls carry the card to the stackers, where a stacker selector causes the card to fall into stacker 1, or allows the card to continue to stacker 0.

Note that cards are transported in a series of steps up to the punch station; once past the ejection rolls, card movement is continuous.

If the punch receives no instruction from the system within a predetermined time, the drive motor stops, but the motor-control circuits remain on.

8-7. OPERATING PROCEDURES

The procedures described in the following paragraphs are those you must perform at the card punch. System operation is described in software operation instructions in other publications.

8-8. Preparation

To prepare the card punch for operation, follow the procedure listed in table 8-2, then load the card punch as follows:

- (1) Load blank cards into the input magazine as described under heading 2-12;
- (2) Press DC ON, MOTOR ON, and OFF LINE pushbuttons to start punch and place it in an off-line status;
- (3) Press ONE CARD and ABNORMAL CLEAR pushbutton alternately three times each to load all card stations; and,

- (4) Press OFF LINE pushbutton to place card punch under system control.

8-9. During Operation

During system operation, your principal tasks will be to load blank cards into the input magazine and remove cards from the output stackers. Loading procedures are described in section 2. To remove cards from the output stackers, wait until a full stacker stops the punch. Don't remove cards from a stacker into which cards are falling. To do so may cause a stacker jam.

Cards may be added to the input magazine while the punch is operating if at least 1 inch of cards remains in the magazine. If fewer cards remain, stop the punch before adding cards. Always replace the magazine weight after adding cards; a weight is required for proper feeding when 1 inch or less of cards remains in the magazine.

Table 8-2. Card-Punch Inspection and Cleaning

Step	Procedure	Remarks
1	Clean card path as follows: Open punch block, brush lint and dust from card path with soft brush. Wipe sensing roll, stacker rolls, and stackers with soft lint-free cloth.	See figures 8-4 and 8-5. Brush assembly opens automatically. Open and close punch block cautiously to avoid slamming block when balance shifts. Do not open block if clutch is engaged. Punch must be off line if system power is on.
2	Inspect brush assembly for damage and wear.	Notify customer engineer if damaged or worn.
3	Inspect for defective lamps in control-panel indicators and in stackers.	Defective lamps cause dark spots in indicators. Notify customer engineer if any lamp is defective.
4	Inspect stacker rolls for loss of tension.	Notify customer engineer of any defects.
5	Inspect card path for loose parts or foreign matter.	
6	Empty chip box.	See figure 8-6.

8-10. In Case of Trouble

Occasionally a card jam may stop the punch. Jams may occur at the stackers, at the punch station, or at the feed throat. Tables 8-3, 8-4, and 8-5 list the procedures for correcting such troubles.

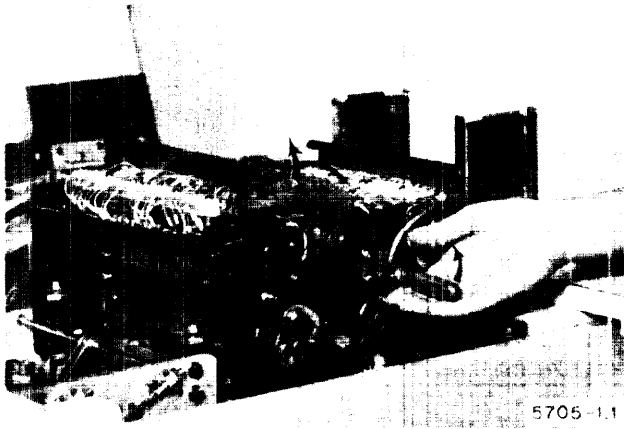
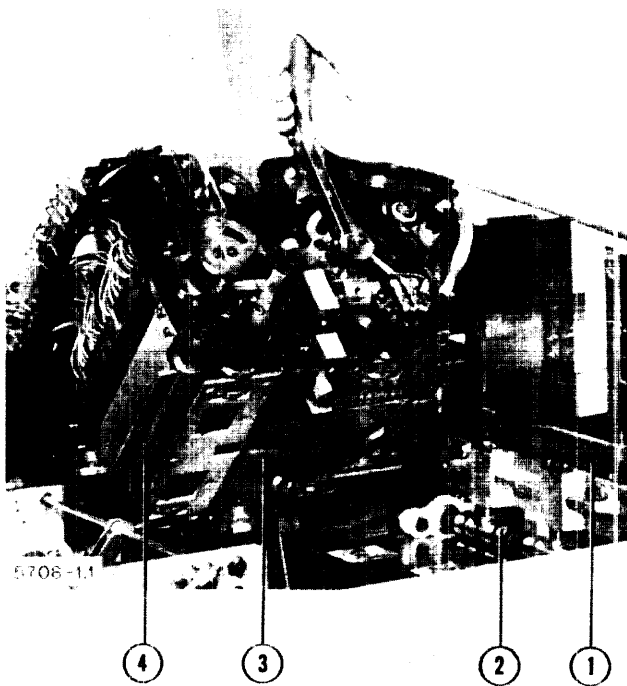

Figure 8-4. Unlocking Punch Block



Figure 8-6. Removing Chip Box



- 1. Feed-Roll Release Bar
- 2. Feed Roll
- 3. Die Block
- 4. Sensing Roll

Figure 8-5. Raising Punch Block

Table 8-3. Clearing Stacker Jams

Step	Procedure	Remarks
1	Press OFF-LINE and DC ON pushbuttons.	OFF-LINE indicator should light, DC ON indicator extinguish.
2	Open punch cover.	
3	Remove jammed cards.	Be sure jam bar returns to normal position. STACK JAM indicator should extinguish.

Table 8-3. Clearing Stacker Jams (cont)

Step	Procedure	Remarks
4	Close cover and press DC ON, MOTOR ON, and ABNORMAL CLEAR pushbuttons.	ABNORMAL CLEAR indicator should extinguish, DC ON and MOTOR ON indicators should light.
5	Press OFF-LINE pushbutton.	OFF-LINE indicator should extinguish.

Table 8-4. Clearing Punch-Station Jams

Step	Procedure	Remarks	
1	Press OFF-LINE and DC ON pushbuttons.	OFF-LINE indicator should light, DC ON indicator should extinguish.	
2	Open punch cover.		
3	Open punch block.	See figures 8-4 and 8-5.	
4	Remove damaged cards from punch station and all cards from feed path.		
5	Clear die slot by passing card through slot from input side.	See figure 8-7.	
6	Close and lock punch block and brush assembly.	See figure 8-8.	
<table border="1"> <tr> <td style="text-align: center;"> <p>CAUTION</p> <p>Close and lock punch block before locking brush assembly.</p> </td> </tr> </table>			<p>CAUTION</p> <p>Close and lock punch block before locking brush assembly.</p>
<p>CAUTION</p> <p>Close and lock punch block before locking brush assembly.</p>			
7	Close punch cover.		
8	Press DC ON, MOTOR ON, and ABNORMAL CLEAR pushbuttons.	DC ON indicator should light, ABNORMAL CLEAR and FEED JAM indicators should extinguish, and MOTOR ON indicator light.	
9	Press ONE CARD pushbutton and ABNORMAL CLEAR pushbutton alternately at least three times each.	Tests card feed and places blank card at punch station.	
10	Press OFF-LINE pushbutton.	OFF-LINE indicator should extinguish.	



Figure 8-7. Clearing Die Slot



Figure 8-8. Locking Brush Assembly

Table 8-5. Clearing Throat Jams

Step	Procedure	Remarks	Step	Procedure	Remarks
1	Press OFF-LINE and DC ON pushbuttons.	OFF-LINE indicator should light, DC ON indicator extinguish.	6	Press DC ON, MOTOR ON, and ABNORMAL CLEAR pushbuttons.	DC ON and MOTOR ON indicators should light. ABNORMAL CLEAR and FEED JAM indicators should extinguish.
2	Open punch cover and punch block.	See figures 8-4 and 8-5.			
3	Remove cards from input magazine and feed track.		7	Press ONE CARD pushbutton and ABNORMAL CLEAR pushbutton alternately at least three times each.	Tests card feed and places blank card at punch station.
4	Pull feed-roll release bar toward magazine, and remove cards from throat.	See figure 8-5.			
5	Close punch block, brush assembly, and punch cover.	See figure 8-8.			
	<div style="border: 1px solid black; padding: 5px; width: fit-content; margin: 0 auto;"> <p>CAUTION</p> <p>Close and lock punch block before locking brush assembly.</p> </div>		8	Press OFF-LINE pushbutton.	OFF-LINE indicator should extinguish.

Section 9

CARD PUNCH MODEL 183

9-1. DESCRIPTION

The UNIVAC Card Punch Model 183 (figure 9-1) is an output unit of the UNIVAC III system. It punches 90-column cards at a rate of 300 cards per minute, under program control, and reads each card to enable the system to test whether the information punched

in the card corresponds exactly to what should have been punched. The card-punch unit consists of a card-handling mechanism, a punch mechanism, a brush-type read station, and control circuits. The card-punch synchronizer and its power supply are in the card-punch unit cabinet, but do not require your attention.

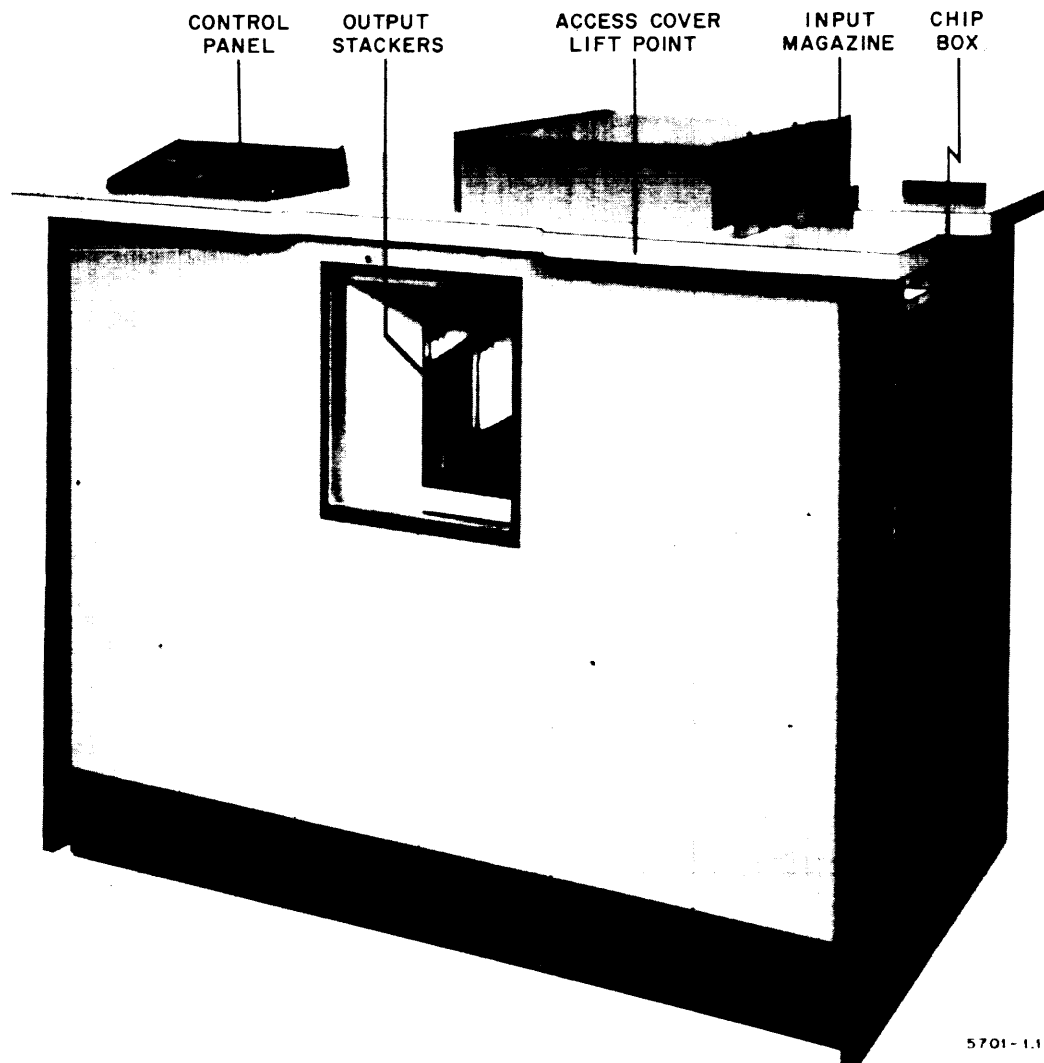

5701-1.1

Figure 9-1. Card Punch Model 183

9-2. Card-Handling Mechanism

The card-handling mechanism consists of a 1000-card input magazine, a card-feed assembly, two wait stations with feed rolls that operate intermittently, a stepping mechanism to feed each card through the punch station one row at a time, two 1000-card output stackers, and four sets of rolls that carry the card away from the punch station, through the read station, and into the output stackers.

The card-handling mechanism feeds cards from the input magazine, carries them to the punch station in a series of steps, and feeds them through the punch station one row at a time. After the card has been punched, the card-handling mechanism carries the cards from the punch station, through the read station, and into the output stackers in a continuous movement. Figure 9-2 shows the card-feed path.

9-3. Punch Station

The punch station and punch assembly are contained in the punch block, which is hinged for access to the card path and punch station. The punch assembly consists of an actuating mechanism, 45 round

punches, and a die block. Cards are punched as they pass between the punches and the die block, through a slot that can pass only one card at a time. The punch block also contains a part of the card-handling mechanism.

9-4. Read Station

The read station consists of a brush holder that contains a row of 45 small wire brushes, all touching a metal sensing roll. As a card passes through a read station, it passes between the brushes and the sensing roll and lifts the brushes from the roll. As the card continues through the read station, any hole in the card allows a brush to touch the sensing roll and pass a signal.

9-5. Control Circuits

The control circuits (1) enable the system, through the synchronizer, to control card feeding, punching, and output-stacker selection, and (2) provide for limited control from the punch-unit control panel. Table 9-1 lists and describes the controls and indicators on the card-punch control panel. Figure 9-3 shows the control panel.

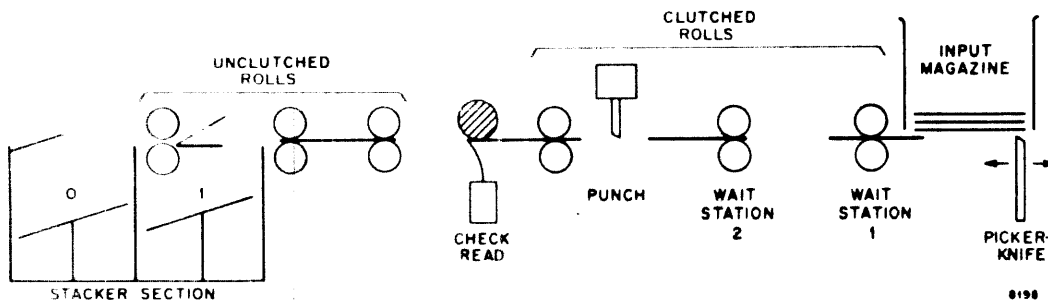

Figure 9-2. Card-Feed Path

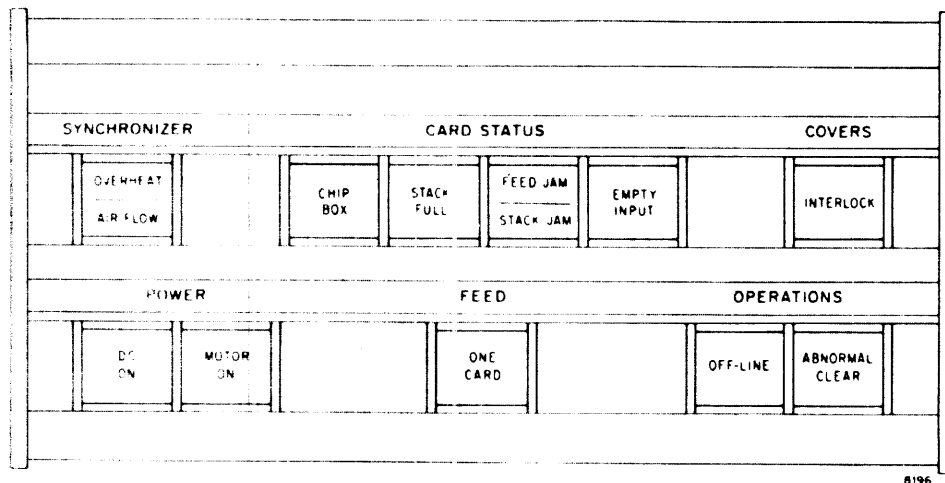

Figure 9-3. Card-Punch Control Panel

Table 9-1. Control Panel, Card Punch Model 183

Component type is abbreviated as follows:

S—Pushbutton (switch) only,
 L—Indicator (lamp) only, and
 S/L—Combined pushbutton and indicator.

Pushbutton or Indicator			Function or Indication
Marking	Color	Type	
SYNCHRONIZER			
OVERHEAT	Red	L	OVERHEAT indicator lights when synchronizer temperature has exceeded 135°F. The d-c power is off.
AIR FLOW			AIR FLOW indicator lights when air flow in synchronizer or power supply has failed or is insufficient. The d-c power is off.
CARD STATUS			
CHIP BOX	Yellow	L	Indicator lights when chip box is full or not in place.
STACK FULL	Yellow	L	STACK FULL indicator lights when a stacker is full.
FEED JAM	Red	L	FEED JAM indicator lights when card jam occurs between input magazine and stacker. Drive motor is off.
STACK JAM			STACK JAM indicator lights when card jam occurs at either stacker. Drive motor is off.
EMPTY INPUT	Yellow	L	Indicator lights when input magazine is empty.
COVERS			
INTERLOCK	Yellow	L	Indicator lights when a cabinet door is open. Drive motor is off.

Table 9-1. Control Panel, Card Punch Model 183 (cont)

Pushbutton or Indicator			Function or Indication
Marking	Color	Type	
POWER			
DC ON	Green	S/L	Indicator lights when d-c power is on. Pressing pushbutton turns on or turns off d-c power.
<div style="border: 1px solid black; padding: 5px; margin: 10px auto; width: 80%;"> <p style="text-align: center;">CAUTION</p> <p style="text-align: center;">Do not turn off d-c power unless unit is off line.</p> </div>			
MOTOR ON	Green	S/L	Indicator lights when motor-control circuits are under system control. Pressing pushbutton once places motor-control circuits under system control. Pressing pushbutton a second time disconnects motor-control circuits from system control and extinguishes indicator.
FEED			
ONE CARD	White	S	Pressing pushbutton causes punch to feed one card. No punching occurs.
OPERATIONS			
OFF-LINE	Blue	S/L	Indicator lights when punch is off line. Pressing pushbutton logically disconnects punch from system control. Pressing pushbutton a second time returns punch to system control.
<div style="border: 1px solid black; padding: 5px; margin: 10px auto; width: 80%;"> <p style="text-align: center;">CAUTION</p> <p style="text-align: center;">Do not press OFF-LINE pushbutton while cards are being fed.</p> </div>			
ABNORMAL CLEAR	Red	S/L	Indicator lights when abnormal condition occurs. Pressing pushbutton clears error circuits in punch synchronizer.

to the information that should have been punched, the system causes the card-punch unit to reject the card by allowing it to continue to output stacker 0. Valid cards fall into stacker 1. At any time during a normal punching cycle, there are three cards in the feed track: one at each wait station, and one in the punch station. Between punching cycles, there are cards at wait stations 1 and 2. Beginning with an empty feed track, the first four card cycles are as follows:

- (1) The card-feed mechanism feeds a card from the input magazine to wait station 1. The card stops until the next card-feed cycle.
- (2) On the next cycle, the card-handling mechanism moves the card at wait station 1 to wait station 2 and feeds another card to wait station 1.
- (3) During the following cycle, the first two steps are repeated, and the card at wait station 2 is stepped through the punch station, one row at a time, to a third wait station.
- (4) During the fourth cycle, the first three steps are repeated, and the card punched during the third cycle is transported by the clutched ejection rolls through the read station and into the stacker rolls. The stacker rolls carry the card to the stackers, where a stacker selector causes the card to fall into stacker 1, or allows the card to continue to stacker 0.

Note that cards are transported in a series of steps up to the punch station; once past the ejection rolls, card movement is continuous.

If the punch receives no instruction from the system within a predetermined time, the drive motor stops, but the motor-control circuits remain on.

9-7. OPERATING PROCEDURES

The procedures described in the following paragraphs are those you must perform at the card punch. System operation is described in software operation instructions in other publications.

9-8. Preparation

To prepare the card punch for operation, follow the procedure listed in table 9-2, then load the card punch as follows:

- (1) Load blank cards into the input magazine as described under heading 2-12;
- (2) Press DC ON, MOTOR ON, and OFF LINE pushbuttons to start punch and place it in an off-line status;

(3) Press ONE CARD and ABNORMAL CLEAR pushbutton alternately three times each to load all card stations; and,

(4) Press OFF LINE pushbutton to place card punch under system control.

9-9. During Operation

During system operation, your principal tasks will be to load blank cards into the input magazine and remove cards from the output stackers. Loading procedures are described in section 2. To remove cards from the output stackers, wait until a full stacker stops the punch. Don't remove cards from a stacker into which cards are falling. To do so may cause a stacker jam.

Cards may be added to the input magazine while the punch is operating if at least 1 inch of cards remains in the magazine. If fewer cards remain, stop the punch before adding cards. Always replace the magazine weight after adding cards: the weight is required for proper feeding when 1 inch or less of cards remains in the magazine.

Table 9-2. Card-Punch Inspection and Cleaning

Step	Procedure	Remarks
1	Clean card path as follows: Open punch block, brush lint and dust from card path with soft brush. Wipe sensing roll, stacker rolls, and stackers with soft lint-free cloth.	See figures 9-4 and 9-5. Brush assembly opens automatically. Open and close punch block cautiously to avoid slamming block when balance shifts. Do not open block if clutch is engaged. Punch must be off line if system power is on.
2	Inspect brush assembly for damage and wear.	Notify customer engineer if damaged or worn.
3	Inspect for defective lamps in control-panel indicators and in stackers.	Defective lamps cause dark spots in indicators. Notify customer engineer if any lamp is defective.
4	Inspect stacker rolls for loss of tension.	Notify customer engineer of any defects.
5	Inspect card path for loose parts or foreign matter.	
6	Empty chip box.	See figure 9-6.

9-10. In Case of Trouble

Occasionally a card jam may stop the punch. Jams may occur at the stackers, at the punch station, or at the feed throat. Tables 9-3, 9-4, and 9-5 list the procedures for correcting such troubles.

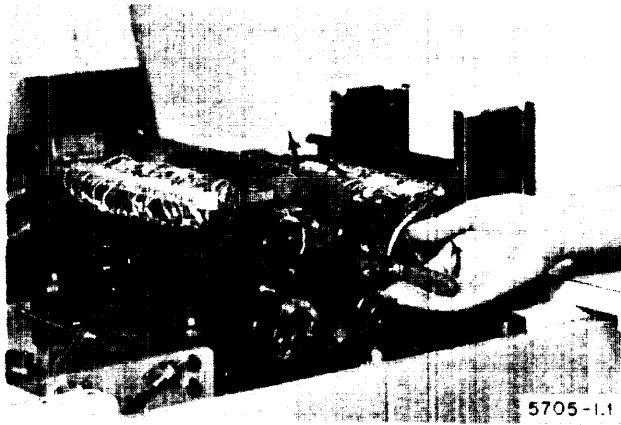
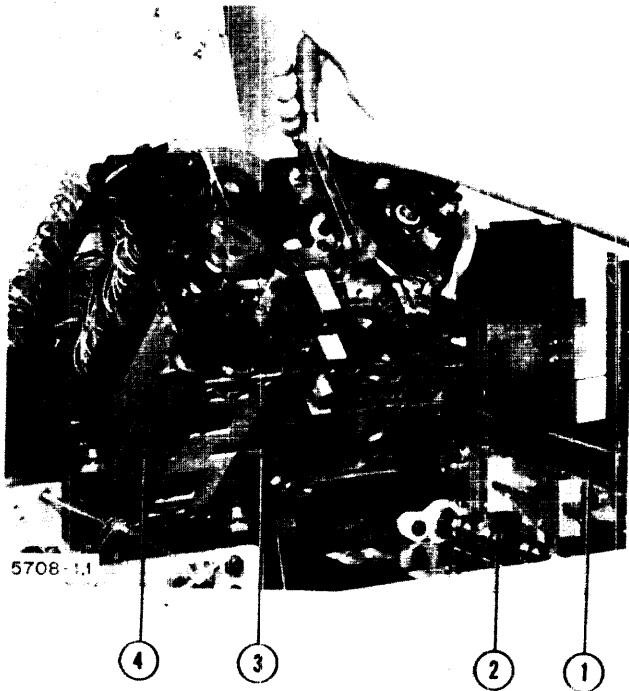

Figure 9-4. Unlocking Punch Block



Figure 9-6. Removing Chip Box



- 1. Feed-Roll Release Bar
- 2. Sensing Roll
- 3. Die Block
- 4. Feed Roll

Figure 9-5. Raising Punch Block

Table 9-3. Clearing Stacker Jams

Step	Procedure	Remarks
1	Press OFF-LINE and DC ON pushbuttons.	OFF-LINE indicator should light, DC ON indicator extinguish.
2	Open punch cover.	
3	Remove jammed cards.	Be sure jam bar returns to normal position. STACK JAM indicator should extinguish.

Table 9-3. Clearing Stacker Jams (cont)

Step	Procedure	Remarks
4	Close cover and press DC ON, MOTOR ON, and ABNORMAL CLEAR pushbuttons.	ABNORMAL CLEAR indicator should extinguish, DC ON and MOTOR ON indicators should light.
5	Press OFF-LINE pushbutton.	OFF-LINE indicator should extinguish.

Table 9-4. Clearing Punch-Station Jams

Step	Procedure	Remarks	
1	Press OFF-LINE and DC ON pushbuttons.	OFF-LINE indicator should light, DC ON indicator should extinguish.	
2	Open punch cover.		
3	Open punch block.	See figures 9-4 and 9-5.	
4	Remove damaged cards from punch station and all cards from feed path.		
5	Clear die slot by passing card through slot from input side.	See figure 9-7.	
6	Close and lock punch block and brush assembly.	See figure 9-8.	
<table border="1"> <tr> <td style="text-align: center;"> <p>CAUTION</p> <p>Close and lock punch block before locking brush assembly.</p> </td> </tr> </table>			<p>CAUTION</p> <p>Close and lock punch block before locking brush assembly.</p>
<p>CAUTION</p> <p>Close and lock punch block before locking brush assembly.</p>			
7	Close punch cover.		
8	Press DC ON, MOTOR ON, and ABNORMAL CLEAR pushbuttons.	DC ON indicator should light, ABNORMAL CLEAR and FEED JAM indicators should extinguish, and MOTOR ON indicator light.	
9	Press ONE CARD pushbutton and ABNORMAL CLEAR pushbutton alternately at least three times each.	Tests card feed and places blank card at punch station.	
10	Press OFF-LINE pushbutton.	OFF-LINE indicator should extinguish.	



Figure 9-7. Clearing Die Slot

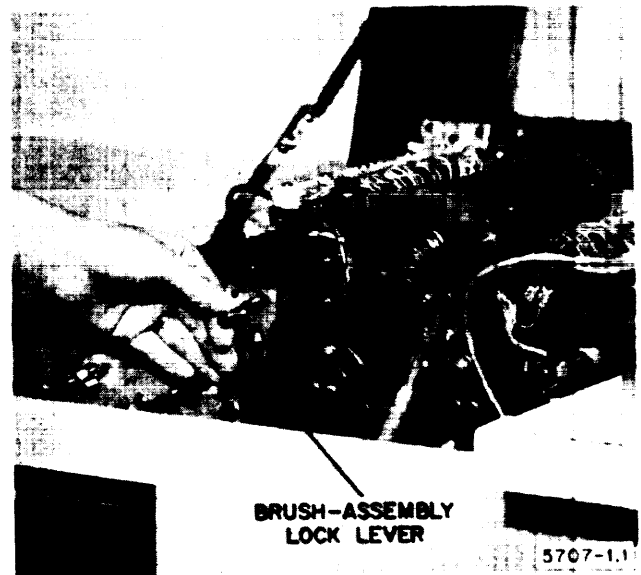

Figure 9-8. Locking Brush Assembly

Table 9-5. Clearing Throat Jams

Step	Procedure	Remarks	Step	Procedure	Remarks
1	Press OFF-LINE and DC ON pushbuttons.	OFF-LINE indicator should light, DC ON indicator extinguish.	6	Press DC ON, MOTOR ON, and ABNORMAL CLEAR pushbuttons.	DC ON and MOTOR ON indicators should light. ABNORMAL CLEAR and FEED JAM indicators should extinguish.
2	Open punch cover and punch block.	See figures 9-4 and 9-5.			
3	Remove cards from input magazine and feed track.		7	Press ONE CARD pushbutton and ABNORMAL CLEAR pushbutton alternately at least three times each.	Tests card feed and places blank card at punch station.
4	Pull feed-roll release bar toward magazine, and remove cards from throat.	See figure 9-5.			
5	Close punch block, brush assembly, and punch cover.	See figure 9-8.			
<div style="border: 1px solid black; padding: 5px; width: fit-content; margin: 0 auto;"> <p>CAUTION</p> <p>Close and lock punch block before locking brush assembly.</p> </div>			8	Press OFF-LINE pushbutton.	OFF-LINE indicator should extinguish.

Section 10

HIGH-SPEED PRINTER MODEL 152

10-1. DESCRIPTION

The UNIVAC High-Speed Printer Model 152 (figure 10-1) consists of two units, a printing mechanism and a printer synchronizer, in a single cabinet. The printer operates on line, that is, as a computer-controlled part of the UNIVAC III system, and can produce printed copy at up to 700 lines per minute with letters and figures intermixed, or at up to 922 lines per minute with figures only. The system program specifies the content and format of the printed copy; the synchronizer, under the direction of the system program, controls the line-by-line operation of the printer.

10-2. Printing Mechanism

The printing mechanism consists of a rotating type drum, a ribbon-transport mechanism, printing actuators and hammers, and a paper transport mechanism. The type drum is a cylinder with raised printing characters. The characters are arranged in sequence around the cylinder, and in rows of the same character along the cylinder. As the type drum revolves, timing circuits control the action of each printing actuator and hammer to cause the hammer to strike the paper when the proper character is opposite the hammer. The hammer strikes the paper with a sharp blow and pinches the ribbon

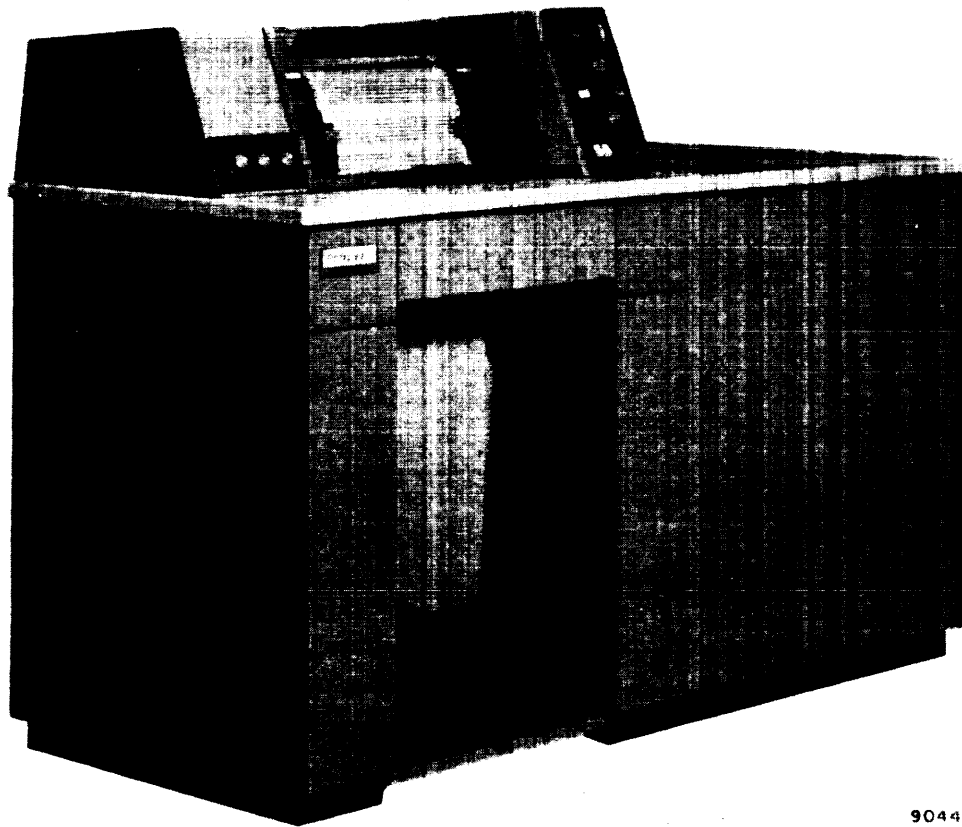

9044

Figure 10-1. High-Speed Printer Model 152

between the paper and the type drum to print each character (figure 10-2).

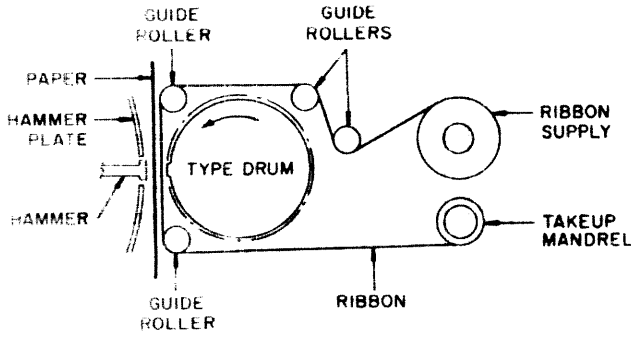

(NOTE RAISED CHARACTER IN PRINTING POSITION)

3535

Figure 10-2. Printing Mechanism, Simplified

The hammer plate and the paper transport are rigidly mounted to the frame of the printer. The type drum and the ribbon transport, however, are in a movable carriage. The carriage moves in toward the hammer plate for printing, and out, away from the printing position, for servicing. The space between the type drum and the hammers can be changed, so that either single-thickness paper or multiple-copy forms may be used to produce equally good printing quality.

The ribbon-transport mechanism moves the ribbon in front of, but not quite touching, the type drum. When all but a short length of ribbon has wound off the supply mandrel, the ribbon-transport mechanism automatically reverses and winds the ribbon in the other direction. The ribbon-transport stops the ribbon one second after printing stops, then starts the ribbon moving again the next time the paper-transport mechanism moves the paper.

The paper-transport mechanism feeds paper, a line at a time, under system control. The system can also cause the printer to perform a fast feed operation to space from one page to another. The mechanism consists of two sets of pin-feed tractors, adjustable for form width from 4 through 22 inches, and for margin placement. The lower set of tractors draws paper from the supply container and passes it to the upper tractors. The tension of the paper between the upper and lower tractors is adjustable and does not vary with the weight of the paper stock. Printed pages pass from the upper tractors between wire guides and out the rear of the printer, where they are collected on a shelf. You can adjust forms for proper placement of printing, the tension of the paper, and the margin settings by using the controls on the printer control panels.

10-3. Controls

Figure 10-3 illustrates the printer-control panels and table 10-1 lists and describes the various indicators and the electrical and mechanical controls.

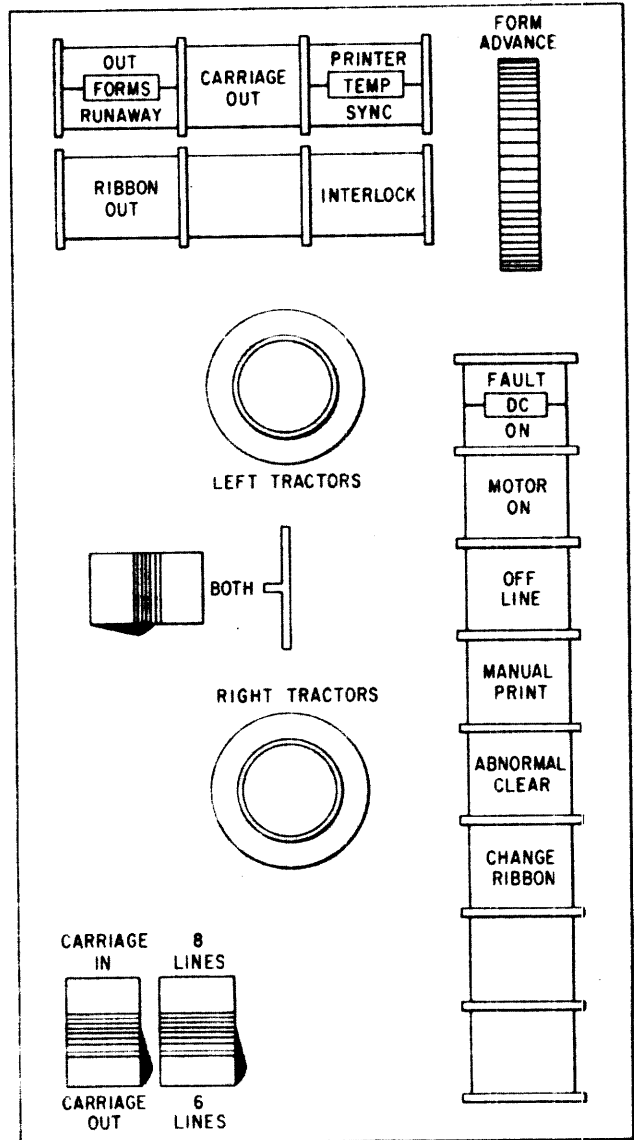

a. Right-Hand Panel

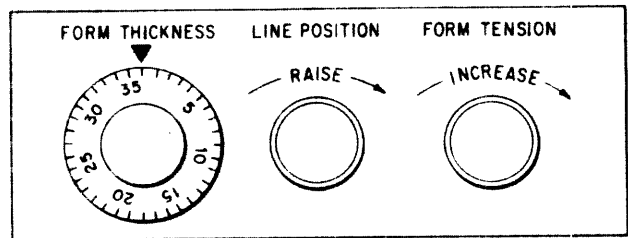

b. Left-Hand Panel

3536

Figure 10-3. High-Speed Printer Controls

Table 10-1. High-Speed Printer Controls and Indicators

a. Indicators and Indicating Controls

Component type is abbreviated as follows:
 S—Pushbutton (switch) only,
 L—Indicator (lamp) only, and
 S/L—Combined switch and indicator.

Control or Indicator			Function or Indication
Marking	Color	Type	
<i>Fault Indicators</i>			
<div style="border: 1px solid black; padding: 5px; width: fit-content; margin: auto;"> OUT <div style="border: 1px solid black; padding: 2px; display: inline-block; margin: 2px;">FORMS</div> RUNAWAY </div>	Red	L	OUT indicator lights when less than 2-1/2 inches of paper remain in the paper-feed path. Printer is stopped. RUNAWAY indicator lights when paper has fed for more than one second without stopping. Printer is stopped.
<div style="border: 1px solid black; padding: 5px; width: fit-content; margin: auto;"> CARRIAGE OUT </div>	Red	L	Indicator lights when carriage is not in printing position. Printer will not operate under program control.
<div style="border: 1px solid black; padding: 5px; width: fit-content; margin: auto;"> PRINTER <div style="border: 1px solid black; padding: 2px; display: inline-block; margin: 2px;">TEMP</div> SYNC </div>	Red	L	PRINTER indicator lights when a temperature above 120° F in the printer unit causes protective circuits to turn off d-c power and stop printer. SYNC indicator lights when temperature above 120° F in synchronizer unit causes protective circuits to turn off d-c power and stop printer.
<div style="border: 1px solid black; padding: 5px; width: fit-content; margin: auto;"> RIBBON OUT </div>	Red	L	Indicator lights when CHANGE RIBBON indicator is lighted and ribbon has wound to normal reversing point on top mandrel. Printer is stopped and d-c power is off.
<div style="border: 1px solid black; padding: 5px; width: fit-content; margin: auto;"> INTERLOCK </div>	Red	L	Lights when a cabinet door is open. The d-c power is off.
<i>Controls</i>			
<div style="border: 1px solid black; padding: 5px; width: fit-content; margin: auto;"> FAULT <div style="border: 1px solid black; padding: 2px; display: inline-block; margin: 2px;">DC</div> ON </div>	Red Green	S/L	FAULT indicator lights when a fault occurs while d-c power is on. ON indicator lights when d-c power is on. Pressing pushbutton turns on d-c power if no fault is present. Pressing pushbutton when DC ON indicator is lighted turns off d-c power and extinguishes indicator.
<div style="border: 1px solid black; padding: 5px; width: fit-content; margin: auto;"> MOTOR ON </div>	Green	S/L	Indicator lights when drive motors are on. When motor is off and no other fault exists, pressing pushbutton starts paper-feed and type-drum drive motors. Pressing pushbutton when drive motor is on turns off drive motors.

Table 10-1. High-Speed Printer Controls and Indicators (cont)

Control or Indicator			Function or Indication
Marking	Color	Type	
OFF LINE	White	S/L	<p>Indicator lights when printer is off line.</p> <p>Pressing pushbutton disconnects printer from system control and lights indicator.</p> <p>Pressing pushbutton when indicator is lighted returns printer to system control and extinguishes indicator.</p>
MANUAL PRINT	White	S/L	<p>Indicator lights when printer is operating in manual-print mode.</p> <p>Pressing pushbutton once when indicator is not lighted causes printer to print continuously the characters in the delay loops in the synchronizer. Pressing pushbutton while printer is operating in manual-print mode stops printing and extinguishes indicator. (Printer must be in off-line status.)</p> <p>The MANUAL PRINT switch is for maintenance purposes only and must not be used by the operator.</p>
ABNORMAL CLEAR	Red	S/L	<p>Indicator lights for following abnormal conditions:</p> <p style="margin-left: 20px;">Motor off, CARRIAGE OUT, RIBBON OUT, Logic error, FORMS RUNAWAY, PRINTER TEMP (overheat), SYNC TEMP (overheat), INTERLOCK, DC FAULT (power-supply fault), and D-C power off.</p> <p>Pressing pushbutton, after condition is corrected, clears error circuits in printer synchronizer and extinguishes indicator.</p>
CHANGE RIBBON	Red	S/L	<p>Pressing switch lights CHANGE RIBBON indicator and disables ribbon-reversing circuits. Ribbon stops at normal reversing point when wound onto top mandrel. (Printer stops and RIBBON OUT, ABNORMAL CLEAR, and DC FAULT indicators light when ribbon stops.)</p> <p>Pressing pushbutton when indicator is lighted returns ribbon reversing circuits to normal operation and extinguishes indicator.</p>

The control circuits (1) enable the system, through the synchronizer, to control printing and paper spacing, (2) stop the printer if any abnormal condition occurs that could cause either improper printing or damage to the printer, and (3) provide for limited control from the printer-control panels. Additional controls on the panels provide mechanical-adjustment facilities for loading paper and aligning forms for proper placement of printing.

10-4. OPERATING PROCEDURES

The operating procedures and tasks listed or described in the following paragraphs are those you

must perform at the high-speed printer. System operation is described in software operating instructions in other publications.

10-5. Before Operation

To prepare the printer for operation, perform the following steps:

- (1) Inspect ribbon. If it is worn or frayed, load new ribbon. Refer to table 10-2 for procedure.
- (2) Load the paper or form required for first run. Refer to table 10-3 for procedure.

(3) When system power is on, turn on printer d-c power. If neither the green DC ON indicator

nor a fault indicator (table 10-1) lights within 10 seconds, notify customer engineer.

Table 10-1. High-Speed Printer Controls and Indicators (cont)

b. Non-Indicating Controls

Control		Function
Marking	Type	
<i>Right-Hand Panel</i>		
FORM ADVANCE	Wheel	Turning wheel operates switch to advance paper, one line at a time. Printer must be off line and stopped.
<div style="border: 1px solid black; padding: 5px; width: fit-content; margin: auto;"> <p style="text-align: center;">CAUTION</p> <p style="text-align: center;">Unlock tractors (push locking levers in) before using RIGHT TRACTORS or LEFT TRACTORS control. Printer must be off line and stopped.</p> </div>		
LEFT TRACTORS	Knob	Turning knob adjusts left-hand paper-feed tractors, except when coupling switch is in BOTH position.
BOTH (Coupling Switch)	Rocker Pushbutton	Pressing BOTH side of rocker pushbutton electrically couples left and right tractor controls. When coupling switch is in BOTH position, turning either tractor-control knob moves both sets of tractors in desired direction without changing spacing between left and right tractors.
RIGHT TRACTORS	Knob	Turning knob adjusts right-hand paper-feed tractors, except when coupling switch is in BOTH position.
CARRIAGE IN CARRIAGE OUT	Rocker Pushbutton	Pressing CARRIAGE IN side of rocker pushbutton causes carriage to move to printing position. Pressing CARRIAGE OUT side of rocker pushbutton causes carriage to move out to servicing position. (CARRIAGE OUT, ABNORMAL CLEAR, and DC FAULT indicators light when carriage is not in printing position.) Printer should be off line.
8 LINES 6 LINES	Rocker Pushbutton	Pressing 8 LINES side of rocker pushbutton sets paper-feed mechanism to feed paper 8 lines to the inch. Pressing 6 LINES side of rocker pushbutton sets paper-feed mechanism to feed paper 6 lines to the inch.
<i>Left-Hand Panel¹</i>		
FORM THICKNESS	Knob	Adjusts space between type drum and print hammers to provide best impression. Turning counterclockwise increases space by 0.001 inch per graduation.
LINE POSITION	Knob	Raises or lowers form slightly to adjust vertical placement of printing.
FORM TENSION	Knob	Adjusts vertical tension of form between upper and lower paper-feed tractors.
<i>Underside of Carriage</i>		
Inching Switch	3-Position Toggle	Transports ribbon under manual control in direction determined by position of switch. Switch must be returned to center position for normal operation.

¹ Controls on left-hand panel may be used while printing.

Table 10-1. High-Speed Printer Controls and Indicators (cont)

b. Non-indicating Controls

Control		Function
Marking	Type	
<i>Left-Hand Side of Carriage</i>		
Codewheel Phasing Control	Knurled Wheel	Adjusts timing of print hammers to ensure that hammers strike entire character. For maintenance only. Must not be used by operator.

Table 10-2. Changing Ribbon

Step	Procedure	Remarks
1	Press CHANGE RIBBON pushbutton.	CHANGE RIBBON indicator should light. Wait until RIBBON OUT indicator lights, then perform the following steps.
2	Press OFF LINE pushbutton and raise transparent cover.	OFF LINE indicator should light.
3	Press carriage rocker switch to CARRIAGE OUT position.	Carriage should move to servicing position, CARRIAGE OUT, DC FAULT, and ABNORMAL CLEAR indicators should light.
4	When carriage stops, unlock both 1/4-turn fasteners under ribbon shield and lower the shield.	See 4, figure 10-10.
5	Raise the carriage cover.	See 5, figure 10-10.
6	Open carton that contains new ribbon. Put on plastic gloves packed in ribbon carton and remove ribbon from carton.	Save carton to dispose of old ribbon.
7	Operate inching switch (underside of carriage) to wind ribbon completely onto top mandrel, then remove old ribbon from printer. To remove ribbon, push mandrel to left, pull out right end.	Place in empty carton for disposal.
8	Remove front guide roller. Push to right to release left-hand end.	See figure 10-4.
9	Unwrap new ribbon and place it on drive hubs, left end first.	See figure 10-5. Ribbon should feed from top of roll. Be sure drive pin enters slot in ribbon mandrel.
10	Pass free end of ribbon to rear, over guide rollers. Reach under bottom of carriage and pull ribbon to front. Wrap several turns around takeup mandrel.	See figure 10-6. Remove mandrel to wrap ribbon, then replace.
11	Replace front guide roller removed in step 8. Insert right-hand end first.	See figure 10-7.

Table 10-2. Changing Ribbon (cont)

Step	Procedure	Remarks
12	Place edge of ribbon in edge-sensing arm. Take up slack by turning takeup mandrel.	See figure 10-8.
13	Remove gloves. Operate inching switch to wind ribbon onto takeup mandrel.	Switch must be returned to center position for system-controlled operation.
14	Lower carriage cover, raise and lock ribbon shield, and press carriage switch to CARRIAGE IN position.	Carriage should move to printing position, CARRIAGE OUT indicator should extinguish.
15	Press CHANGE RIBBON, ABNORMAL CLEAR, and OFF LINE pushbuttons. Close transparent cover.	CHANGE RIBBON, RIBBON OUT, ABNORMAL CLEAR, OFF LINE and D-C FAULT indicators should extinguish.



Figure 10-4. Removing Front Guide Roller

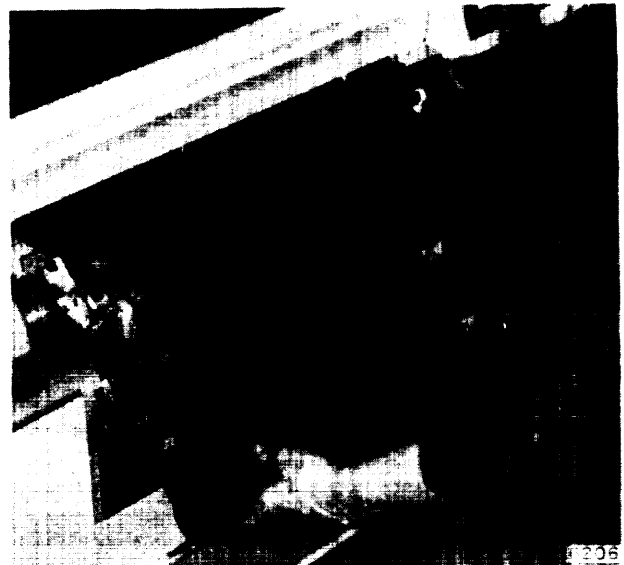

Figure 10-6. Starting Ribbon on Takeup Mandrel



Figure 10-5. Loading New Ribbon



Figure 10-7. Replacing Front Guide

Table 10-3. Loading Paper

Step	Procedure	Remarks
1	Press OFF LINE pushbutton and raise transparent cover.	OFF LINE indicator should light.
2	Press four tractor lock levers in to unlock tractors.	See figure 10-9 (lower tractors not shown). Omit this step and steps 4, 5, 6, 8, 10, 11, 12, and 13 if reloading same form.
3	Open tractor pressure plates and press carriage rocker switch to CARRIAGE OUT position.	See figure 10-9. Carriage should move to servicing position. CARRIAGE OUT, DC FAULT, and ABNORMAL CLEAR indicators should light.
4	Press tractor coupling switch away from BOTH position.	Uncouples tractor controls. Omit if reloading same form.
5	Move left-hand tractors to approximate left margin for new form.	Omit if reloading same form.
6	Move right-hand tractors to about 2 inches from right-hand edge of new form.	Omit if reloading same form.
7	Place supply of paper or forms on supply shelf. Pass paper up between carriage and hammer plate. Insert in left-hand tractors (top tractor first) and close pressure plate.	See figure 10-10. Shelf slides out to receive supply, slides in for operation.
8	Align right-hand tractor pins with sprocket holes of form.	See figure 10-11. Omit if reloading same form.
9	Insert paper in right-hand tractors and close pressure plates.	
10	Move right-hand tractors carefully to right to place forms under slight side-to-side tension.	Omit if reloading same form.
11	Press tractor coupling switch to BOTH position. Adjust margin setting by turning either tractor control knob.	Omit if reloading same form.
12	Pull out four tractor lock levers to lock tractors.	Omit if reloading same form.
13	Press carriage rocker switch to CARRIAGE IN position.	Carriage should move to printing position. CARRIAGE OUT indicator should extinguish.
14	Turn FORM ADVANCE wheel to set form to proper starting point.	Starting point varies with form and program. Refer to run book or software operating instructions.
15	Press ABNORMAL CLEAR pushbutton and OFF LINE pushbutton.	Both indicators should extinguish.

#

10-6. During Operation

During operation, your principal tasks are to reload paper or change forms and to remove and label finished pages. For labeling instructions, refer to your run book.

10-7. After Operation

At the end of a run, or at the end of the last run during your shift, remove and label all printed pages. If the first run of the following shift requires a different form, unload the forms you used.

Return blank forms to stock unless you know they will be needed by the operator who follows you.

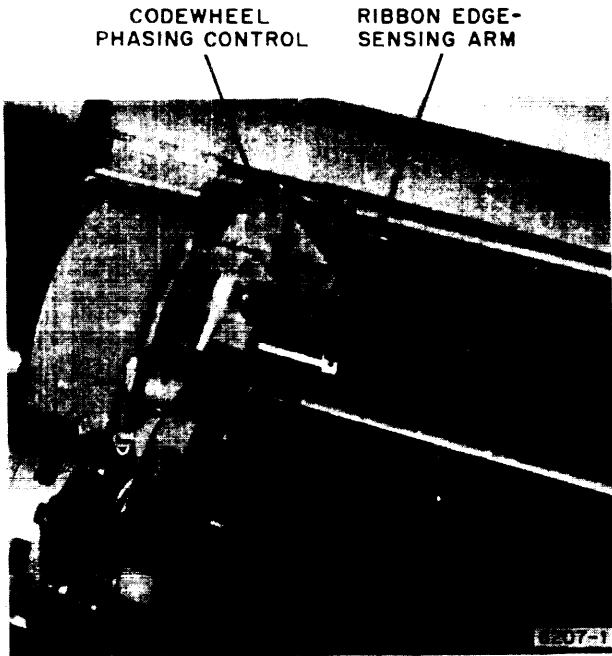
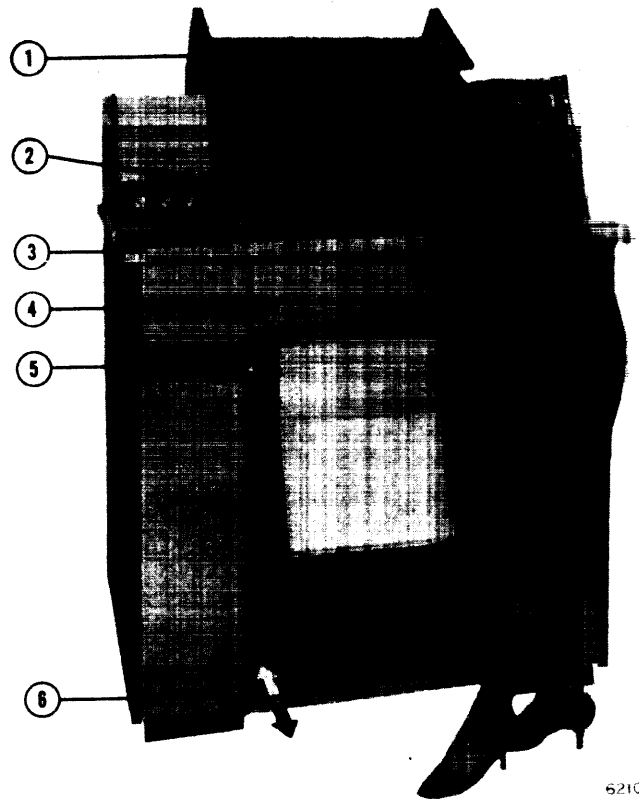

Figure 10-8 Ribbon Edge Sensing Switch



1. Transparent Cover
2. Upper Tractor Assembly (Left-Hand Tractor Shown)
3. Carriage Cover
4. Ribbon Cover
5. Lower Tractor Assembly (Left-Hand Tractor Shown)
6. Paper Shelf

Figure 10-10. Inserting Paper

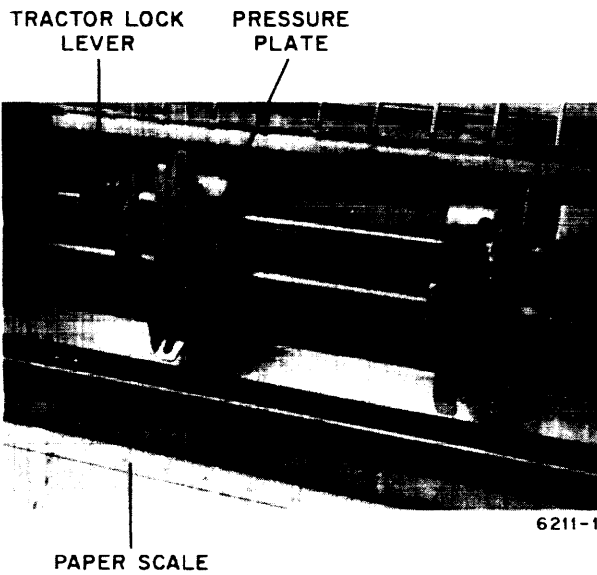

Figure 10-9. Paper-Feed Tractors



Figure 10-11. Adjusting Tractors

10-8. In Case of Trouble

The following paragraphs describe the actions you should take for certain troubles that may occur during printing.

10-9. PAPER FAULTS. If paper tears during a run, reload the paper. If the paper tears again, look for excess form tension; if necessary, adjust the **FORM TENSION** control. If paper continues to tear, or if any paper fault that occurs cannot be cleared, notify the customer engineer. After any paper fault that causes loss or incorrect placement of printed data, refer to the operating instructions

for the program in use to find out how to recover the lost data.

10-10. FAULTY PRINTING. If characters appear misaligned or are missing, or if lines are skipped, notify the customer engineer. If print becomes too light, inspect the ribbon. If the ribbon is dry or torn, replace it. If the ribbon is in good condition, verify the setting of the **FORM THICKNESS** control and correct it if necessary. If neither the ribbon nor the **FORM THICKNESS** control is causing the trouble, notify the customer engineer. If any data is lost through faulty printing, refer to the operating instructions for the program in use to determine how to recover the lost data.

Section 11

PAPER-TAPE READ/PUNCH UNIT MODEL 181

11-1. DESCRIPTION

The Paper-Tape Read/Punch Unit Model 181 (figures 11-1, 11-2) provides input-output compatibility with telegraphic communications systems or with business systems that use perforated tape equipment.* The unit consists of a photoelectric reader, an 8-channel punch, spoolers for the reader and punch, a synchronizer, and a power supply. The reader and punch are in the upper section of the unit; the synchronizer and the power supply are in the lower section.

Both the reader and the punch can operate with 11/16-inch, 7/8-inch, or 1-inch tape, and can punch and read tape in 5-, 6-, 7-, or 8-channel code.

11-2. Reader and Reader Spooler

The photoelectric reader can read tape at 250 or 500 characters per second and stop within one character. When the reader operates with spooled tapes at these speeds, the reader spooler operates as a servomechanism; that is, the spooler responds

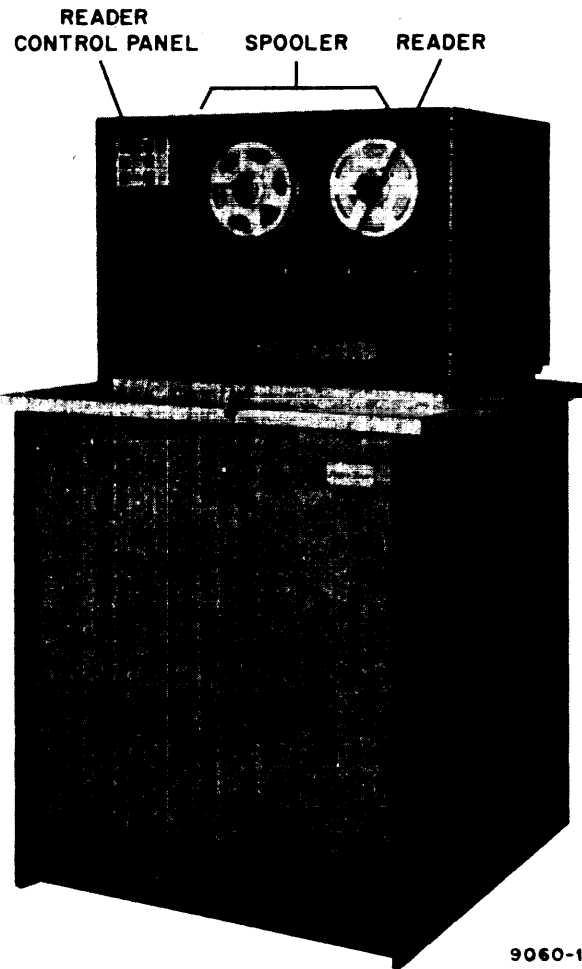

Figure 11-1 Paper Tape Read/Punch Unit Model 181, Reader Side

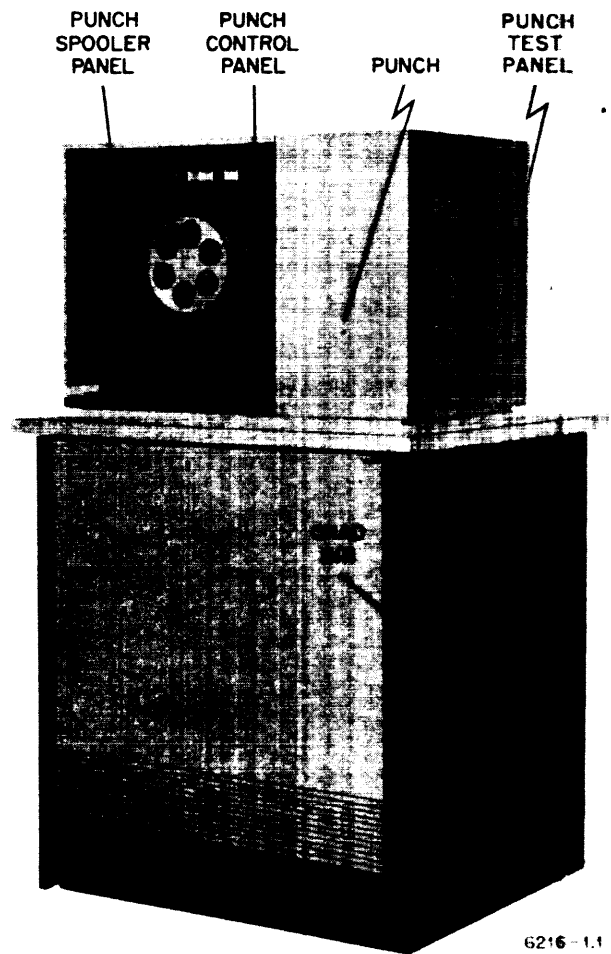

Figure 11-2. Paper Tape Read/Punch Unit Model 181, Punch Side

*Except systems that use chadless tape; photoelectric readers cannot read chadless tape.

to changes in tape length and tension between the reader and the tape reels, and operates only when the reader moves tape.

The third operating speed enables the reader to read spooled tapes non-stop, at an average speed of at least 1500 characters per second. At this speed, the reader does not move the tape; the takeup-reel motor of the spooler pulls the tape through the reader. Tapes for the reader may be on 8-inch or 10-1/2-inch reels, or in unspooled strips of any convenient length.

The reader (figure 11-3) consists of a photocell assembly, an exciter lamp, two capstan-and-pinch-roller assemblies, two brake assemblies, and two variable-width tape guides. The capstans rotate continuously, in opposite directions; the left-hand capstan rotates in a clockwise direction. The brakes are electromagnetically operated and are normally on. They release when the pinch rollers engage, and engage when the pinch rollers release, except during a rewind or high-speed forward operation. When on, the upper brake lever clamps the tape against the brake surface.

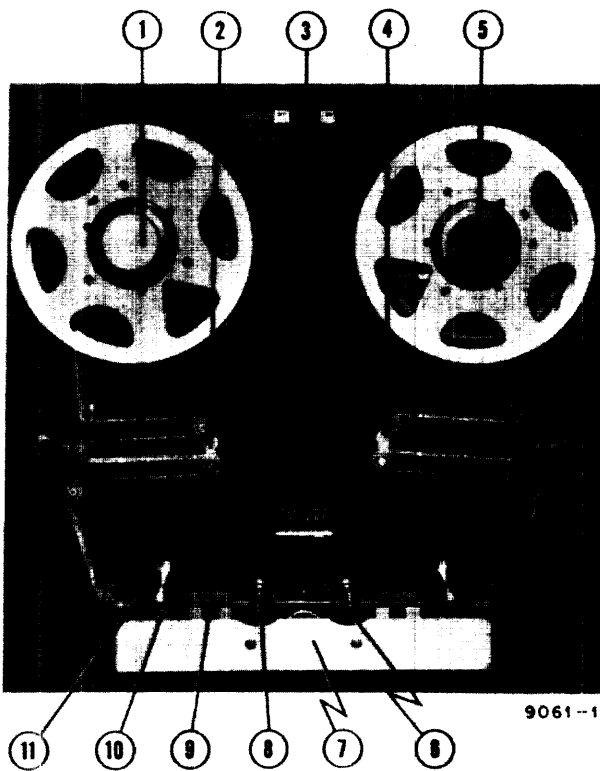

- | | |
|-----------------------|-----------------------|
| 1. Takeup Reel | 6. Exciter Lamp |
| 2. Takeup Tension Arm | 7. Photocell Assembly |
| 3. POWER Switch | 8. Tape Guide |
| 4. Supply Tension Arm | 9. Brake |
| 5. Supply Reel | 10. Pinch Roller |
| | 11. Capstan |

Figure 11-3. Tape Handler and Panels

To transport tape from the supply reel to the takeup reel, the left-hand pinch roller pinches the tape against the rubber-faced capstan. The rotating capstan grips the tape and pulls it past the photocell assembly. To stop the tape, the pinch roller releases and the brakes engage. To transport tape from left to right, the right-hand pinch roller engages and the right-hand capstan pulls the tape through the reader. During a rewind or high-speed forward operation, both the pinch rollers and the brakes disengage, and the spooler pulls tape through the reader.

11-3. Punch and Punch Spooler

The paper-tape punch (figure 11-4) operates at 110 characters per second. Tape passes from the supply reel through the punch, and may be threaded to the takeup reel or allowed to run free (dashed line on figure) into a basket or other suitable container.

The supply reel and the takeup reel are driven by servo-motors. The supply spooler (figure 11-4) feeds

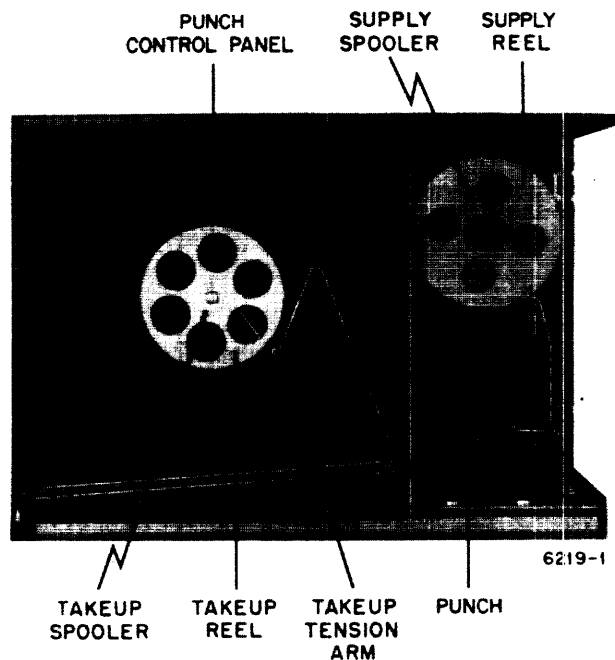

Figure 11-4. Punch, and Takeup Spooler Panel

out tape to the punch to maintain a slight slack between supply reel and punch. Too much tension could cause torn sprocket holes, overpunching, or torn tape. The takeup reel winds up punched tape as it is delivered from the punch. The takeup tension arm regulates the takeup-reel drive motor.

11-4. Controls

The control circuits (1) enable the system, through the synchronizer, to control tape reading and punching; (2) stop the reader, punch, or entire unit if

any abnormal condition occurs; and (3) provide for limited control from the reader and punch control panels. A format connector (heading 11-5) provides control of the reading and punching format. Table 11-1 lists and describes the external controls and indicators on the reader side of the paper-tape unit. Table 11-2 lists and describes the external controls and indicators on the punch side of the paper-tape unit. Figures 11-5 and 11-6 show the external control panels.

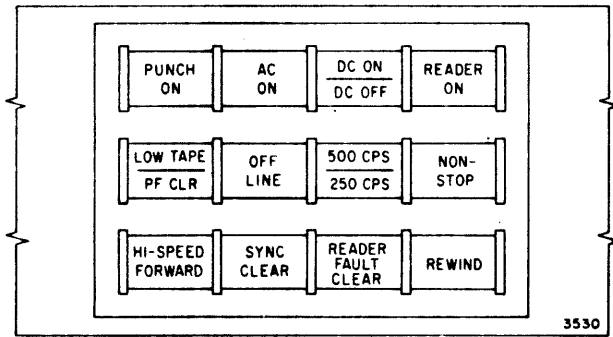

Figure 11-5. Reader Control Panel

11-5. Format Connector

The format connector (figure 11-8) is a wired plug that is used to determine the format of information punched in output tapes. The run book will specify which format connector to use when paper tape is used during a run.

11-6. OPERATING PROCEDURES

The procedures described in the following paragraphs are those you must perform at the paper-tape unit. System operation is described in software operating instructions in other publications.

11-7. Preparation: Daily Inspection and Cleaning

To prepare the paper-tape unit for operation, perform the steps listed in table 11-3.

11-8. During Operation

During system operation, your principal tasks will be to load and change tapes on the reader and punch.

Tables 11-4 through 11-6 give detailed instructions for performing these tasks. Procedures for adjusting the tape-feed mechanisms for various tape widths are given under heading 11-9; the procedure for changing format connectors is given under heading 11-10.

11-9. ADJUSTING FEED MECHANISM FOR TAPE WIDTH. To adjust the reader tape-feed mechanism to the correct width for the tape to be used, pull or push each tape guide (figure 11-3) to the width of the tape. Detents in the guide assembly hold the guide in position at each of three positions.

To adjust the punch tape-feed mechanism to the correct width for the tape to be used, first pull or push the tape guide (figure 11-7) to the width of the tape. Then, when loading the supply reel (table 11-6), use a spacing ring as necessary (for narrow tapes) to hold the tape supply against the rear flange. (The tape must be flush against the rear flange to hold the low-tape sensing arm (figure 11-7) in the correct position.) The outer flange on the takeup reel is reversible, with a spacing collar on one side, to accommodate different tape widths.

11-10. CHANGING FORMAT CONNECTOR. To change the format connector (figure 11-8), perform the following steps:

- (1) Turn connector lock screw counterclockwise to unlock connector.
- (2) Pull out connector.
- (3) Align index pin on socket with hole in new connector, and push connector into socket.
- (4) Turn connector lock screw clockwise to lock connector in place.

11-11. In Case of Trouble

If a malfunction or abnormal condition occurs that cannot be corrected from the external control panels, notify the customer engineer. To splice a torn tape, follow the instructions for the equipment you have. If a malfunction or torn tape causes the loss of information, either on a reader tape or on punch-output tape, notify your supervisor.

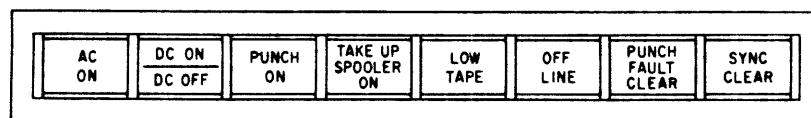

Figure 11-6. Punch Controls Panel

Table 11-1. Reader Controls and Indicators

Component type is abbreviated as follows:

- S - Pushbutton (switch) only.
- L - Indicator (lamp) only, and
- S/L - Combined pushbutton and indicator.

Pushbutton or Indicator			Function or Indication
Marking	Color	Type	
PUNCH ON	Green	L	Indicator lights when punch is on.
AC ON	Green	L	Indicator lights when a-c power is on in paper-tape unit.
DC ON <hr/> DC OFF	Green Red	S/L	DC ON indicator lights when d-c power is on. DC OFF indicator lights when a-c power is on and d-c power is off. Pressing pushbutton turns on or turns off d-c power, when a-c power is on.
READER ON	Green	S/L	Indicator lights when reader is on. Pressing pushbutton turns on or turns off reader when d-c power is on.
LOW TAPE <hr/> PF CLR	Yellow Red	S/L	LOW TAPE indicator lights when less than 80 inches of tape remain on the punch supply reel. PF CLR (Punch Fault Clear) indicator lights when a punch fault condition exists. Pressing pushbutton after fault has been corrected clears punch fault circuits and extinguishes indicators.
OFF LINE	White	S/L	Indicator lights when paper-tape unit is off line. Pressing pushbutton disconnects unit from system control. Pressing pushbutton a second time returns unit to system control.
500 CPS <hr/> 250 CPS	Green White	S/L	500 CPS indicator lights when reader speed is 500 characters per second. 250 CPS indicator lights when reader speed is 250 characters per second. Pressing pushbutton alternately selects reader speed of 500 CPS or 250 CPS.
NON STOP	White	S/L	Indicator lights when reader is operating in non-stop mode. Pressing pushbutton selects non-stop (1500 CPS) mode of reading.

Table 11-1. Reader Controls and Indicators (cont¹)

Pushbutton or Indicator			Function or Indication
Marking	Color	Type	
HI-SPEED FORWARD	Green	S	Pressing pushbutton causes reader spooler to wind tape forward (to left-hand reel) at full speed. Operation continues only while pushbutton is depressed. Do not press pushbutton while tape is moving.
SYNC CLEAR	White	S	Pressing pushbutton clears entire paper-tape-unit synchronizer to initial state.
READER FAULT CLEAR	Red	S/L	Indicator lights when fault condition exists in reader portion of paper-tape unit circuits. Pressing pushbutton clears fault circuits in reader portion of synchronizer.
REWIND	White	S/L	Indicator lights when rewind operation is in progress. Pressing pushbutton causes reader spooler to rewind tape (to right-hand reel). Do not press pushbutton while tape is moving.
POWER ON-OFF	—	Toggle Switch	See figure 11-3. Pushing switch handle turns on or turns off power to spooler motors, and to reader brakes and pinch rollers. Unit need not be off line.

Table 11-2. Punch Controls and Indicators

Component type is abbreviated as follows:

- S — Pushbutton (switch) only,
- L — Indicator (lamp) only, and
- S/L — Combined pushbutton and indicator.

Pushbutton or Indicator			Function or Indication
Marking	Color	Type	
AC ON	Green	L	Indicator lights when a-c power is on in paper-tape unit.
DC ON DC OFF	Green Red	L	DC ON indicator lights when d-c power is on in paper-tape unit. DC OFF indicator lights when d-c power is off in paper-tape unit. Neither indicator lights if a-c power is off, if an interlocked door is open, if the unit has overheated, or if the cooling fans have stopped.

Table 11-2. Punch Controls and Indicators (cont)

Pushbutton or Indicator			Function or Indication
Marking	Color	Type	
PUNCH ON	Green	S/L	Indicator lights when punch-control circuits are on. Pressing pushbutton turns on or turns off punch-control circuits.
TAKE-UP SPOOLER ON	Green	S/L	Indicator lights when spooler power is on. Pressing pushbutton turns on or turns off power to spooler. Pushbutton is effective only when punch motor is on.
LOW TAPE	Yellow	L	Indicator lights when less than 80 inches of tape remain on punch supply reel.
OFF LINE	White	L	Indicator lights when paper-tape unit is off line.
PUNCH FAULT CLEAR	Red	S/L	Indicator lights when fault condition exists in punch portion of paper-tape unit circuits. Pressing pushbutton clears fault circuits in punch portion of synchronizer.
SYNC CLEAR	White	S	Pressing pushbutton clears entire paper-tape-unit synchronizer to initial state.
PCH MOT	—	Toggle Switch	Pushing switch handle to START position starts punch motor. (Switch is on punch test control panel, figure 11-7.)

Table 11-3. Inspection and Cleaning

Step	Procedure	Remarks	Step	Procedure	Remarks
1	Empty chad bin.	See figure 11-8.	4	Observe photocell assembly for exciter-lamp beam.	Notify customer engineer if any lamp is defective. Unit may be operated with defective indicator lamps.
2	Feel format connector lock-screw. Tighten if necessary. Be sure it is the correct format connector!		5	Observe indicators for dark spots that indicate defective lamps.	
3	Turn on d-c power.				

Table 11-4. Removing Tape From Reader

Step	Procedure	Remarks
1	Press OFF LINE push-button on control panel.	OFF LINE indicator should light.
2	If tape has not been completely rewound, press REWIND push-button on control panel. If it is not necessary to rewind tape, when reader is stepped, press and hold HI-SPEED FORWARD pushbutton until operation is completed.	Tape should wind onto right-hand reel. Press push-button again when operation is finished. Tape should wind onto left-hand reel.
3	Push spooler POWER switch handle to OFF position.	See figure 11-3.
4	Turn supply-reel locking knob counterclockwise to a positive stop.	Reel should release.
5	Remove reel.	

Table 11-5. Loading Tape on Reader

Step	Procedure	Remarks
1	Push spooler POWER switch handle to OFF position.	
2	Place loaded reel on supply-reel hub. Push firmly to seat reel.	Be sure takeup reel is large enough.
3	Turn locking knob clockwise firmly until it is hand tight.	
4	Thread tape through tension rollers and reader. Insert free end in retaining slot in takeup reel, and wind several turns of tape onto reel.	See figure 11-3. If width of tape is different from width of last tape used, refer to heading 11-9.
5	Push spooler POWER switch handle to ON position.	Reels should adjust slack.
6	Press READER FAULT CLEAR pushbutton.	READER FAULT CLEAR indicator should extinguish, if lighted.

Table 11-5. Loading Table on Reader (cont)

Step	Procedure	Remarks
7	Press 500 CPS/250 CPS pushbutton or NON-STOP pushbutton to select desired reading speed.	Indicator should light to show speed selected. Do not use 500 CPS with 10-1/2-inch reels; do not use NON-STOP with strips.

Table 11-6. Loading Tape on Punch

Step	Procedure	Remarks
1	Press PUNCH ON pushbutton.	PUNCH ON indicator should extinguish.
2	Open punch door.	
3	Unload takeup spooler. Remove either outer flange or entire reel.	See figure 11-7. Replace inner flange and hub when reel is empty.
4	Unscrew and remove outer flange from supply reel.	See figure 11-7.
5	Load tape on supply reel and replace outer flange.	Reel should turn counterclockwise as tape feeds from reel. If tape width is different from width of last tape used, refer to heading 11-9.
6	Pull off about three feet of tape. Pass free end over feedout tension arm.	See figure 11-7.
7	Thread end of tape through punch.	If tape will not pass through slot, turn main shaft by hand to raise sprocket punch. See figure 11-7.
8	Raise tape lid and pull several feet of tape through punch. Press lid firmly to close.	See figure 11-7.
9	Push PCH MOT (punch motor) switch handle to START position, then release.	Punch motor should start. See figure 11-7.

Table 11-6. Loading Tape on Punch (cont)

Step	Procedure	Remarks	Step	Procedure	Remarks
10	Hold feed out lever down. Gently pull free end of tape until feed wheel feeds tape. Feed at least three feet of tape.	See figure 11-7. Repeat step 10 if necessary.		or out, as required by tape width.	
11	Finish threading. Fold end of tape and insert in slot in takeup reel hub (if spooler is used).	See figure 11-4 for alternate tape paths.	13	Close door.	
12	Wind several turns of tape on takeup-reel hub. Replace flange with spacing collar in	Collar should be in for wide tapes, out for narrow tapes (heading 11-9).	14	Press PUNCH ON pushbutton.	PUNCH ON indicator should light.
			15	Press PUNCH SPOOLER ON pushbutton if spooler is to be used.	PUNCH SPOOLER ON indicator should light.
			16	Press PUNCH FAULT CLEAR pushbutton.	LOW TAPE and PUNCH FAULT indicators should extinguish.

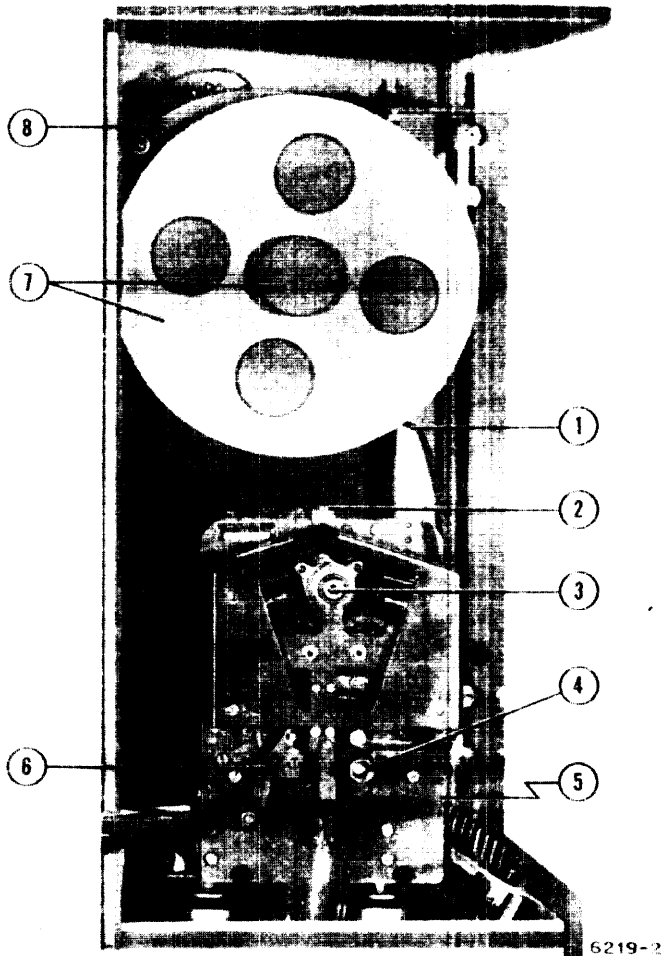

- 1. Feedout Tension Arm
- 2. Feedout Lever
- 3. Main Shaft
- 4. Tape Guide
- 5. PCH MOT switch (on Punch Test Panel)
- 6. Tape Lid
- 7. Supply Reel Flange and Knob
- 8. Low Tape Sensing Arm

Figure 11-7. Punch and Supply Spooler

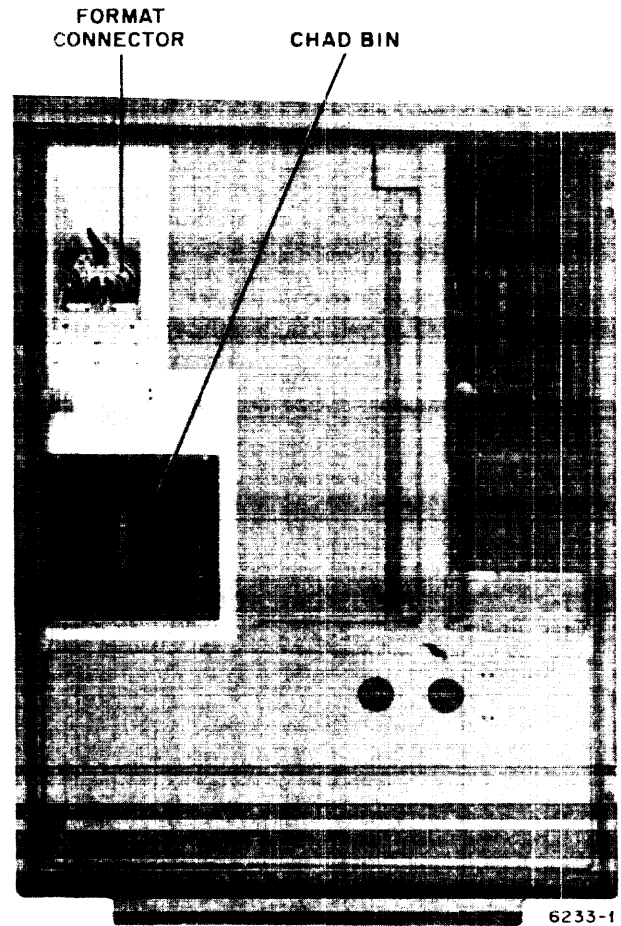
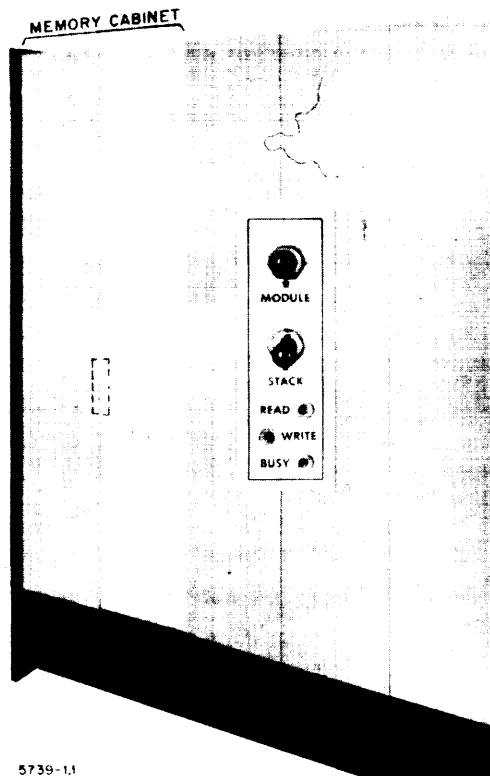

Figure 11-8. Format Connector and Chad Bin

Section 12 MAGNETIC CORE MEMORY

12-1. GENERAL

The UNIVAC III system uses a magnetic core memory arranged in 4096-word units, called stacks. A system may use as few as two, or as many as eight memory stacks, in two-stack multiples. Two stacks constitute a module; a cabinet (figure 12-1) may contain one or two modules. In a four-stack (two module) unit, the stacks are designated A, B, C, and D. Figure 12-2 shows the arrangement of the stacks and modules and shows the addresses assigned to each stack in the first memory cabinet during normal operation.



5739-11

Figure 12-1. Memory-Stack Switch Location

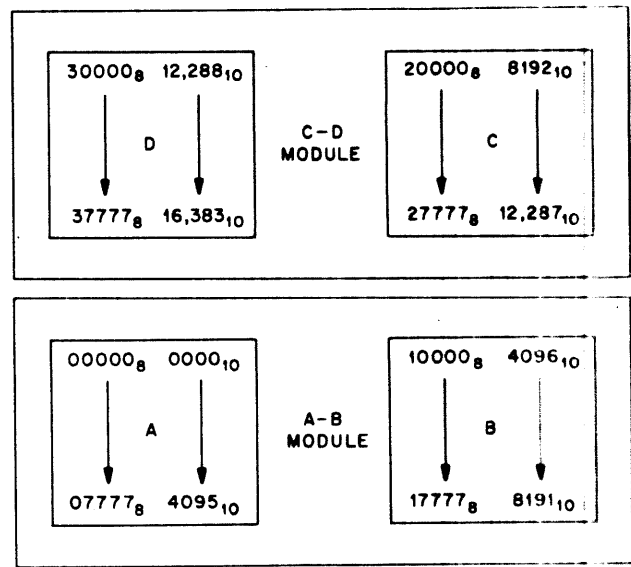

Figure 12-2. Memory Arrangement

12-2. MEMORY SWITCHES

In a four-stack memory cabinet, two switches (figure 12-1) enable you to change the address assignments of the four stacks. In effect, it is possible to change the address assignments of any one stack to those of any other stack. Tables 12-1 and 12-2 list the effects of operating the memory switches in the four possible combinations. The addresses are shown to the nearest thousand; that is, 0-4 instead of 0000-4095.

To change memory address assignments, find the row in table 12-1 or table 12-2 that shows the desired arrangement, then operate the switch (or switches) indicated at the left-hand end of the row. Table 12-1 shows addresses assigned to the first four memory stacks (cabinet 1). Table 12-2 shows the addresses assigned to the memory stacks in the second of two memory cabinets (cabinet 2) in a system that uses a second cabinet.

Table 12-1. Effects of Memory-Switch Operation, Cabinet 1

CAUTION

Do not operate the memory switches while a program is running. The program will lose the information in memory if you do.

Switches Operated	Addresses in Stack			
	A	B	C	D
<i>Normal Address Assignments</i>				
Neither	0-4	4-8	8-12	12-16
<i>Modified Address Assignments</i>				
Stack Switch	4-8	0-4	12-16	8-12
Module Switch	12-16	8-12	4-8	0-4
Both Switches	8-12	12-16	0-4	4-8

Table 12-2. Effects of Memory-Switch Operation, Cabinet 2

CAUTION

Do not operate the memory switches while a program is running. The program will lose the information in memory if you do.

Switches Operated	Addresses in Stack			
	A	B	C	D
<i>Normal Address Assignments</i>				
Neither	16-20	20-24	24-28	28-32
<i>Modified Address Assignments</i>				
Stack Switch	20-24	16-20	28-32	24-28
Module Switch	28-32	24-28	20-24	16-20
Both Switches	24-28	28-32	16-20	20-24